



# Navy Crane Center



## NAVFAC P-307 Training

### GENERAL CRANE SAFETY REFRESHER WEB BASED TRAINING STUDENT GUIDE NCC-GCSR-05

Naval Facilities Engineering Command  
Navy Crane Center  
Norfolk Naval Shipyard, Bldg. 491  
Portsmouth, VA 23709-5000  
Comm. Phone: 757.967.3803, DSN: 387  
Fax: 757.967.3808  
<https://ncc.navfac.navy.mil/>



## TABLE OF CONTENTS

<b>INTRODUCTION .....</b>	<b>5</b>
<b>CRANE TYPES AND COMPONENTS .....</b>	<b>8</b>
<b>OPERATOR'S DAILY CHECKLIST (ODCL) .....</b>	<b>24</b>
<b>DETERMINING LOAD WEIGHT .....</b>	<b>50</b>
<b>LOAD WEIGHT DISTRIBUTION .....</b>	<b>64</b>
<b>SLING ANGLE STRESS .....</b>	<b>73</b>
<b>COMPLEX AND NON-COMPLEX LIFTS .....</b>	<b>85</b>
<b>CRANE COMMUNICATIONS .....</b>	<b>94</b>
<b>CRANE TEAM CONCEPT .....</b>	<b>108</b>
<b>LOAD CHART REVIEW .....</b>	<b>118</b>
<b>RIGGING GEAR TEST, INSPECTION, AND MARKING REQUIREMENTS .....</b>	<b>129</b>
<b>RIGGING GEAR GENERAL USE .....</b>	<b>139</b>
<b>SLING USE .....</b>	<b>148</b>
<b>SAFE OPERATIONS .....</b>	<b>162</b>
<b>SAFE OPERATIONS MODULE 2 .....</b>	<b>173</b>
<b>CRANE AND RIGGING ACCIDENTS .....</b>	<b>188</b>
<b>GENERAL CRANE SAFETY REFRESHER EVALUATION SHEET .....</b>	<b>198</b>



## **INTRODUCTION**

### Welcome

Welcome to General Crane Safety Refresher.

### Introduction

General Crane Safety Refresher is designed to refresh crane operators with Navy requirements for the safe operation of cranes.

Topics covered include crane inspection and lift types, crane communications, crane team concepts, safe operation and lifting requirements, determining load weight and rigging considerations, calculating capacities, and crane and rigging accident identification and response.

### Learning Objectives

Upon successful completion of this course, you will be able to perform an Operator's Daily Checklist, identify crane and lift types, determine load weights, load weight distribution, and sling angle stress, identify proper selection and use of rigging gear, explain the crane team concept, identify proper crane communication methods, and identify crane and rigging accidents.

### References

A copy of the NAVFAC P-307 and Student Guides are available on the Navy Crane Center website: <https://ncc.navfac.navy.mil/Popular-Links>

### Welcome

Welcome to General Crane Safety Refresher.

### Introduction

General Crane Safety Refresher is designed to refresh crane operators with Navy requirements for the safe operation of cranes.

Topics covered include:

- Crane Inspection and Lift Types
- Crane Communications
- Crane Team Concept
- Safe Operation and Lifting Requirements
- Determining Load Weight and Rigging Considerations
- Calculating Capacities
- Crane and Rigging Accident Identification and Response

### Course Learning Objectives

Upon successful completion of this course, you will be able to:

- Identify crane types and components
- Complete an Operator's Daily Checklist
- Determine load weights, load weight distribution, and sling angle stress
- Identify proper selection and use of rigging gear
- Explain the crane team concept
- Identify proper crane communication methods
- Identify crane and rigging accidents

### References

Click on your choice from the reference links below.

[NAVFAC P-307](#)

[View or Print Student Guides](#)

## Getting the Most Out of this Course

To get the most out of this training, pay close attention to the narrations and information provided on each screen. There may be information in the narration that is not shown on the screen. And vice versa, there may be information on the screen that is not contained in the narration. Replay narrations and screen content as often as needed by clicking on the topic title or the tab title as applicable. Complete all knowledge checks and module quizzes to help reinforce your understanding of the material covered.

### Getting the Most Out of this Course

To get the most out of this online course, you should

- Pay attention to narrations and screens (narration and screen information may differ)
- Replay as needed
- Complete knowledge checks and learning activities



The learning activities will help reinforce your learning and prepare you for the module and final assessments.

## Navigating the Course

As you navigate through this course, you will find several helpful tools and features that will facilitate your learning. This interactivity enables you to easily navigate and access various training aids and tools using the following buttons: The navigation buttons (top right) look like arrow heads and allow you to move forward to the next screen or back to the previous screen by clicking on the arrowhead pointing to the right or left, respectively. The 'pause' and 'continue' buttons (top right) allow you to pause and continue (or start) the course or module. The 'exit' button (top right) closes the module and returns you to the main module menu. The 'view and hide narration' links (lower right on the content screen) allow you to view and/or hide a text version of the audible narration.

### Navigating the Course

Interactive navigation features help to:

- facilitate your learning
- access various learning tools

Buttons include:

- the **navigation buttons** which allow you to move to the next or previous screen
- the **pause and continue** buttons which stop and start the course
- the **exit** button which closes the module
- the **view narration** link which allows you to view a text version of the audible narration

## Knowledge Checks

These courses use various types of questions to help you retain the material presented. As you proceed through each topic, you will be asked questions in the form of knowledge checks. The knowledge checks will help you prepare for the module quizzes and final exam. Question types include Fill in the Blank, Drag and Drop, Multiple Choice - Single Answer, Multiple Choice - Multiple Answer, and True/False.

### Knowledge Checks

- Most topics contain **Knowledge Checks**
- Knowledge checks will help you prepare for module quizzes and the final exam
- The questions asked during the presentation and on the exam will be in the form of:
  - Fill in the Blank
  - Drag and Drop
  - Multiple Choice - Single Answer
  - Multiple Choice - Multiple Answer
  - True/False

## Exam Directions

When taking exams, keep the following in mind. Some questions require multiple answers and have check boxes next to the choices. Single answer questions have circles next to the choices. If you score less than 80% on a module quiz, review the necessary content, then return to retake the quiz. You can go back and review any content prior to taking a quiz or final exam. You can review and change your answers any time before you select the "Score Exam" button. A score of 80% or higher is required to pass.

## Feedback

Upon completion of the training, or at any time during the training, please feel free to provide feedback to Navy Crane Center on how to improve or better deliver this presentation. Include suggestions such as: Current WHE accidents, near misses, and trends (with narratives and pictures); Content changes, additions, and deletions; Other topics; Clarifications, corrections, and delivery methodologies. Contact information is provided on the screen and in the student guide. You can come back to this screen at any time prior to passing the final exam. After passing the final exam, the course will roll up, your information will go to "My Transcripts," and the course content will no longer be available. However, you may still refer to the student guide for contact information, or you can go to the Navy Crane Center's training web page and provide feedback via the links found there.

## Ready to Begin

You are now ready to begin your training. Navigate back to the main module menu, select the next module, and begin your training. Good luck.

### Exam Directions

Read each question carefully and select the best answer or answers.

- Multiple answers - square check boxes
- Single answer - round check circles
- If you score less than 80% on a module quiz, review the necessary materials and return to take the quiz
- Review any topic or module prior to taking a quiz or final exam
- Final exam answers may be changed any time prior to selecting the "Score Exam" button
- A score of 80% or higher is required to pass the final exam

### Feedback

Please provide feedback to the presenter and/or Navy Crane Center on how to improve or better deliver this presentation. Include suggestions such as:

- Current WHE accidents, near misses, trends (with narratives and pictures)
- Content change suggestions (i.e., additions, deletions, modifications)
- Other topics
- Clarifications, corrections
- Delivery methodologies

Navy Crane Center  
Norfolk Naval Shipyard, Bldg. 491  
Portsmouth, VA 23709-5000

757-967-3803, DSN 387 (general)  
757-967-3833 (training)  
757-967-3808/3799 (fax)

[nfsh\\_ncc\\_training@navy.mil](mailto:nfsh_ncc_training@navy.mil) (email)

### Completion

You are now ready to begin your training.

Click on the exit button to return to the main module menu, then select and highlight a module title by clicking on it; finally click where indicated to launch the lesson.

## CRANE TYPES AND COMPONENTS

### Welcome

Welcome to Crane Types and Components.

---

---

---

### Learning Objectives

Upon successful completion of this module, you will be able to define and identify crane types, critical crane components, load bearing parts, load controlling parts, and operational safety devices.

---

---



---

### Category 1 Cranes

This is a list of some of the more common types of category 1 cranes. Category 1 cranes come in a wide variety of sizes and configurations and include: portal cranes, hammerhead cranes, locomotive cranes, derricks, YD floating cranes\*, tower cranes, container cranes, mobile cranes, aircraft crash cranes, mobile boat hoists including self-propelled and towed types, and rubber-tired gantry cranes. They are considered category 1 cranes regardless of capacity. All category 1 cranes require a license to operate. \*Note: Other cranes on barges or floating mountings are the category of the crane itself, for example, monorail, jib crane, gantry crane.

---

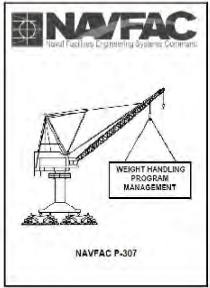
---



**Welcome**

Welcome to Crane Types and Components.

Begin

### Learning Objectives

Upon successful completion of this module, you will be able to define and identify:

- Crane types
- Critical crane components
- Load bearing parts
- Load controlling parts
- Operational safety devices

### Category 1 Cranes

Category 1 Cranes include:

- Portal Cranes
- Hammerhead Cranes
- Locomotive Cranes
- Derricks
- YD Floating Cranes\*
- Tower Cranes
- Container Cranes
- Mobile Cranes
- Aircraft Crash Cranes
- Mobile Boat Hoists
- Rubber Tire Gantry Cranes

\* Other cranes on barges or floating mountings are the category of the crane itself, e.g., monorail, jib crane, gantry crane.



### Category 1 Crane Examples

Here, and on the next few slides, are some un-narrated pictures and descriptions of different types of category 1 cranes. Use the forward and backward arrows to scroll through and review the various examples and their descriptions.

#### Category 1 Crane Examples

##### Floating Cranes

These types of cranes include barge, pontoon, or hull mounted with an integral base.

The luffing booms are capable of continuous 360 degrees rotation.

They are powered by diesel-electric generators, diesel-driven hydraulic pumps, and may be self-propelled and/or tug assisted.



---

---

---

#### Category 1 Crane Examples

##### Container Cranes

Container cranes have hinged booms and main beams with traveling trolleys mounted on rails, which in turn, is mounted on a traveling gantry structure.

These cranes are used at several military port activities to quickly transfer containers on and off ships.



---

---

---

#### Category 1 Crane Examples

##### Hammerhead Cranes

Hammerheads have a rotating counterbalanced cantilevered boom equipped with one or more trolleys that move along the length of the boom.

Most are supported by a pintle or turntable mounted to a traveling or fixed tower assembly.



---

---

---

#### Category 1 Crane Examples

##### Derricks

This crane has a boom that is hinged near the base of a fixed mast.

Typically, the boom rotates left and right between the mast support legs or "stiff legs." These stiff legs are capable of handling tensile and compressive forces.

The pictured crane is referred to as a stiff-leg derrick and can rotate 180 degrees.



---

---

---

**Category 1 Crane Examples**

**Portal Cranes**

Portal cranes consist of a rotating superstructure mounted on a gantry structure. The gantry style structure allows for the free movement of traffic and materials when the crane is located on the pier.

There is an operator's cab, machinery house, and a luffing boom.

The primary source of power is a diesel engine that drives generators or hydraulic pumps.

They are supported by wide gauge rails allowing the portal crane to move about the facility.



---



---



---

**Mobile Boat Hoist**

A mobile boat hoist consists of a steel structure of rectangular box sections, supported by four sets of wheels capable of straddling and carrying boats.

---



---



---

**Landing Craft Retrieval Unit**

A Landing Craft Retrieval Unit, or LCRU, is a type of mobile boat hoist with self-propelled or towed carriers consisting of a wheeled steel structure capable of straddling and carrying boats.

---



---



---

**Category 1 Crane Examples**

**Mobile Cranes**

The most common type of mobile crane is the truck mounted hydraulic crane.

These cranes consist of a rotating superstructure mounted on a specialized truck chassis equipped with a power plant, driver's cab, and operator's cab.

The primary source of power for these types of cranes are diesel engines that drive hydraulic pumps and provide electric power.



---



---



---

**Mobile Boat Hoist**

**Straddle type carrier:**

- steel structure of rectangular box sections
- supported by four sets of wheels
- are capable of straddling and carrying boats



**Mobile Boat Hoist: LCRU**

**Landing Craft Retrieval Unit:**

- Self propelled or towed
- Steel structure on wheels
- Capable of straddling and carrying boats

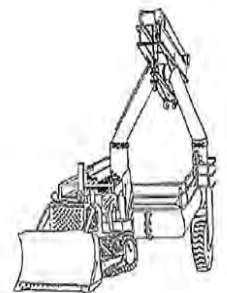

---

## Rubber Tire Gantry

A rubber-tired gantry crane may be single beamed or double beamed. Often, it resembles a mobile bridge crane with its hoist mounted on a bridge which spans two beams. As shown in the illustration, it may be configured with two hoists mounted on opposing beams which utilize a spreader bar or similar mechanism to lift loads. The gantry style legs allow the crane to hover overloads improving stability. The wheels and rubber tires may be motorized or non-motorized.

---



---



---

## Category 4 Crane Examples

**Screen 1, Description:** Typically, category 4 cranes are independently manufactured boom mechanisms that are subsequently attached to or mounted on commercially available trucks. These cranes are operated independent of the vehicle controls from standard ground control stations and may be powered by the truck engine or a power sending unit. The booms may rotate or articulate. Outriggers or stabilizers shall be used as required.

---



---



---

## Screen 2, Booms and Mounts

**Booms and Mounts:** Category 4 cranes have different types of boom configurations such as telescoping, non-telescoping, and articulating. They may be mounted on flatbed trucks, trailers, stake beds, rail cars, barges and pontoons, or may be stationary mounted on piers, wharves, and docks.

---



---



---

### Rubber Tired Gantry Crane



- Portable elevated bridge crane or hoist(s) mounted on legs
- Legs mounted on rubber tires
- May be self-propelled or towed

### Category 4 Crane Descriptions and Examples

#### General

- are manufactured booms
- mounted on commercial trucks
- operated independently
- may be powered by the truck
- may be powered by power sending unit
- outriggers shall be used



### Category 4 Crane Descriptions and Examples (Continued)

#### Booms

- Telescoping
- Non-telescoping
- Articulating

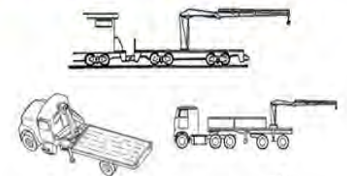

#### Mounts

- Flatbed Trucks
- Trailers
- Stake Beds
- Railcars
- Barges, Pontoons
- Piers, Wharves, Docks

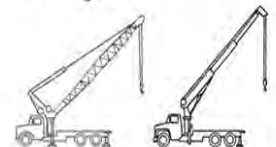

### Screen 3, Capacities & Categories

Capacities and Categories: Pedestal mounted commercial fixed length and telescoping boom assembly cranes with less than 2,000 pounds capacity are considered category 3 cranes. Capacities greater than 2,000 pounds are category 4 cranes.

---

---

---

### Screen 4, Standards & Licensing

Standards and Licensing: Commercial truck mounted cranes as described in ASME B30.5 and articulating boom cranes as described in ASME B30.22 of all capacities are category 4 cranes and require a licensed operator - even if the crane is down rated for administrative purposes.

---

---

---

### Category 2 and 3 Cranes

Category 2 and Category 3 cranes include: overhead traveling cranes; gantry cranes; wall cranes; jib cranes; davits; pillar cranes; pillar jib cranes; monorails and associated hoists; fixed overhead hoists, including fixed manual and powered hoists; portable hoists used continuously in a single location, that is, 6 months or more; portable A-frames and portable gantries with permanently installed hoists; and pedestal mounted commercial boom assemblies attached to stake trucks, trailers, flatbeds, or railcars, or stationary mounted to piers, etc., with certified capacities less than 2,000 pounds.

---

---

---

#### Capacities & Categories

##### Pedestal Mounted Fixed Length and Telescoping Booms:

- If less than 2,000 pounds capacity, it's a category 3 crane.
- If greater than 2,000 pounds capacity, it's a category 4 crane

Category 4 cranes require a licensed operator.



#### Category 4 Cranes: Standards & Licensing

##### Review Standards:

- ASME B30.5
- ASME B30.22

All capacities require a licensed operator.



#### Category 2 and 3 Cranes include:

- Overhead Traveling Cranes
- Rail Mounted Gantry Cranes
- Wall Cranes
- Jib Cranes
- Davits
- Pillar Cranes
- Pillar Jib Cranes
- Monorails and Associated Hoists
- Fixed Overhead Hoists
  - Manual
  - Powered
- Portable hoists used continuously in a single location (6 months or more, 12 months for shipboard availabilities)
- Portable A-frames and portable gantries with permanently installed hoists
- Pedestal mounted commercial boom assemblies with certified capacities less than 2,000 pounds

### Category 2 and 3 Cranes: Capacity

The category of a category 2 or 3 crane is determined by its certified capacity. Category 2 cranes have a certified capacity of 20,000 pounds and greater. Category 3 cranes are those with a certified capacity of less than 20,000 pounds.

---

---

---

#### Certified Capacity Separates Category 2 and 3 Cranes

- Category 2 cranes have a capacity of 20,000 lbs. or greater.
- Category 3 cranes have a capacity of less than 20,000 lbs.

### Category 2 and 3 Crane Examples

Here, and on the next few slides, are some unnarrated pictures and descriptions of different types of category 2 and 3 cranes. Use the forward and backward arrows to scroll through and review the various examples and their descriptions.

**Category 2 and 3 Crane Examples**

**Bridge or Overhead Electric Traveling Cranes**

- May be cab, pendant, or radio controlled
- Principal parts include the bridge, girders, end trucks, trolley, hoist, and controls.
- Mobility is limited to the height of the bay, length of the runway, and the span of the bridge.



---

---

---

**Category 2 and 3 Crane Examples (Continued)**

**Jib Cranes**

Jib cranes are normally category 3 cranes but can be category 2 cranes.

They consist of a horizontal boom that is either cantilevered or supported by tie rods and is capable of rotating left and right. They're equipped with either powered or manual hoists and may have trolleys.

They are usually mounted on a wall or column.



---

---

---

**Category 2 and 3 Crane Examples (Continued)**

**Pillar Jib Cranes**

This is a fixed crane consisting of a rotating vertical member with a horizontal arm supporting a trolley and hoist.

Pillar-jib cranes normally rotate 360 degrees.



---

---

---

**Category 2 and 3 Crane Examples (Continued)**

**Trolley Mounted Overhead Hoists**

These cranes consist of an under-hung trolley with one or more drums and sheaves for wire rope or chain.

They are powered manually, electrically, hydraulically, or pneumatically.

Mobility is limited to the height and length of the supporting beam.



---

---

---

Knowledge Check

1. **Select the best answer to fill in the blank.** A floating crane with a capacity of 200,000 lbs. is a \_\_\_\_\_ crane.
- A. Category 1
  - B. Category 2
  - C. Category 3
  - D. Category 4

2. **Select the best answer.** What is the category of this crane?
- A. Category 1
  - B. Category 2
  - C. Category 3
  - D. Category 4

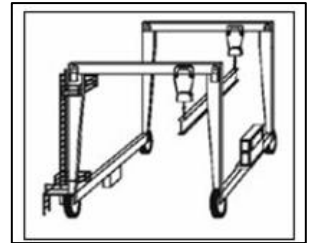

3. **Select the best answer.** What is the category of a jib crane with a capacity of less than 20,000 pounds?
- A. Category 1
  - B. Category 2
  - C. Category 3
  - D. Category 4
4. **Select the best answer to fill in the blank.** An OET Bridge crane with a capacity of 80,000 lbs. is a \_\_\_\_\_ crane.
- A. Category 1
  - B. Category 2
  - C. Category 3
  - D. Category 4
5. **Select the best answer to fill in the blank.** A commercial truck mounted crane with a capacity of 14,000 lbs. is a \_\_\_\_\_ crane.
- A. Category 1
  - B. Category 2
  - C. Category 3
  - D. Category 4

### Types of Power

Category 1 and 4 cranes generally use electric or hydraulic power that is supplied by a diesel engine. A collector ring system conveys electrical current from the revolving portion of the crane to the lower crane structure.

---

---

---

### Category 2 and 3 Crane Power

Category 2 and 3 cranes may be manually-operated or power-operated. A manually-operated crane hoist mechanism is driven by pulling an endless chain. The crane travel mechanism is driven in the same manner or by manually moving the load or hook. A power-operated crane is driven by electric, pneumatic, hydraulic, or internal combustion means. Pneumatic and hydraulic power may be delivered to the crane via pipes and/or hoses. Electricity or current is usually carried from the building or shore power to the bridge and trolley by an insulated electrification conductor system, festoon system, or cable track system.

---

---

---

### Category 1 and 4 Crane Components

The principal parts of most Category 1 and 4 cranes are the boom, machinery house, roller path or rotate bearing, supporting structure, and travel system.

---

---

---

#### Power Types

There are two types of power generally used on Category 1 and 4 cranes:

- Electric Power
- Hydraulic Power



#### Category 2 and 3 Crane Power



Category 2 and 3 cranes may be manually-operated or power-operated.

A power-operated crane is driven by electric, pneumatic, hydraulic, or internal combustion means.

Current is carried from the building or shore power to the bridge and trolley of category 2 and 3 cranes by:

- an insulated electrification conductor system
- a festoon system
- a cable track system

#### Category 1 and 4 Crane Components



The principal parts of most Category 1 and 4 cranes are:

- Boom
- Machinery house
- Roller path or Rotate bearing
- Supporting structure
- Travel system



### Category 2 and 3 Crane Components

The principal parts of overhead traveling cranes are bridge girders, end trucks, trolley with hoisting mechanism, and operator's cab or pendant control.

---

---

---

### Critical Crane Components

Careful repair and maintenance are essential to safe crane operations. To ensure repairs are not compromised by sub-standard parts, critical crane components are clearly identified. NAVFAC P-307, Appendix F provides examples of load bearing parts, load controlling parts, and operational safety devices.

---

---

---

### Load-Bearing Parts

Load-bearing parts support the load. Failure of a load-bearing part can cause dropping, uncontrolled shifting, or uncontrolled movement of the load. There are many different load bearing parts; this picture shows three examples.

---

---

---

### Category 2 and 3 Crane Components



The principal parts of overhead traveling cranes are:

- Bridge girders
- End trucks
- Trolley with hoisting mechanism
- Operator's cab or pendant control

### Critical Crane Components

- Load-Bearing Parts
- Load-Controlling Parts
- Operational Safety Devices



### Load-Bearing Parts



- support the load
- failure can cause dropping, shifting, or uncontrolled movement

### Examples

Examples of load-bearing parts are wire rope, sheaves, hooks, hook blocks, hoist drum pawls, and a boom dog used to prevent unwanted rotation of a boom or hoist drum.

---

---

---

### Carrier Frame Structures

The carrier frame provides a working base for the upper works of the crane. The tires, wheels, and axles support the carrier frame for transporting and for lifting loads on rubber. Outriggers, stabilizers, and locking devices provide support for on-outrigger operations. Failure of any one of these components or systems can cause the load to drop or cause uncontrolled movement of the load. These are critical components that must be carefully checked before operations or testing.

---

---

---

### Load Bearing Parts on Bridge Cranes

Two examples of load-bearing parts found on bridge cranes include the bridge girders that carry the weight of the trolley including hoisting machinery and the load and the wire rope drum and hoisting machinery that lifts and supports the load. Appendix F of NAVFAC P-307 provides additional examples of load-bearing parts.

---

---

---

**Load-Bearing Part Examples**



Wire Rope, Hooks, and Blocks

Sheaves

Boom Dog

**Additional Examples**

- Carrier Frame
- Tires, Wheels, and Axles
- Outrigger beams, Jacks, and Devices



**Load-Bearing Parts on Bridge Cranes**

- Bridge Girders
- Wire Rope Drum and Hoisting Machinery



### Load-Controlling Parts

Load-controlling parts are crane components that position, restrain, or control movement of the load. Malfunction of these parts can cause dropping, uncontrolled shifting, or movement of the load. Shown are two examples of load controlling parts.

---

---

---

### Examples 1

Examples of load-controlling components are foot-controlled brakes used as secondary brakes for hoist speed control, travel gear assemblies, rotate gear assemblies, and rotate locks. Appendix F of NAVFAC P-307 provides additional examples of load-controlling parts.

---

---

---

### Examples 2

Some additional examples are crane-mounted diesel engines and generators, electrical-power-distribution systems, and electrical crane-control circuits related to rotate and travel including brakes and clutches.

---

---

---

#### Load-Controlling Parts

- position, restrain, or control movement
- Malfunction could cause dropping, uncontrolled shifting, or movement of the load



#### Load-Controlling Parts: Examples



Foot-controlled Brakes

Travel Gear Assemblies

Rotate Gear Assemblies

#### Load-Controlling Parts: Examples 2



The following must be treated as load-controlling parts:

- Diesel Engines and Generators
- Electrical Power Distribution System
- Electrical Control Circuits
  - Swing Control
  - Travel Control

## Safety Devices

Safety devices are divided into two groups, general safety devices and operational safety devices. Operational safety devices affect the safe lifting and handling ability of the equipment. Operational safety devices are critical crane components. General safety devices provide protection for personnel and equipment on or in the crane operating path.

---

---

---

### Safety Devices

#### Operational Safety Devices

- affect the safe load lifting and handling capabilities of the equipment

#### General Safety Devices

- provide protection for operations and maintenance personnel and equipment on or in the crane's operating path

## General Safety Devices

General safety devices are those devices that protect or alert the operator or personnel working in the vicinity of the crane. Some general safety devices used to warn personnel working on or around the crane are horns, bells, whistles, travel alarms, and travel warning lights.

---

---

---

### General Safety Devices

General safety devices are those devices that protect or alert the operator or personnel working in the vicinity of the crane.

General safety devices include:

- Horns
- Bells
- Whistles
- Travel alarms
- Travel warning lights

## Operational Safety Devices

### Load Moment Indicators

Load-moment indicators are operational aids providing the crane operator necessary information to stay within the capacity of the crane. Load-moment indicators that provide shutdown capabilities are operational safety devices. They may provide the operator with load weight, boom angle, and boom length. As the operator approaches critical limits, load moment devices may sound an audible alarm, illuminate warning lights, or lock out functions that could possibly allow the operator to overload the crane. If a load moment device has lockout capability, it must be treated as an operational safety device.

### Load-Moment Indicators



- Used as operational aids
  - Provides overload protection
  - Load moment indicators with shutdown capability are operational safety devices
- 
-

### Angle Indicators

Mechanical boom angle indicators are operational safety devices. These devices provide the operator with the boom angle needed to calculate the radius of the crane. Mechanical boom angle indicators are usually mounted on the boom where they can easily be read from the cab.

---

---

---

**Operational Safety Devices: Angle Indicators**

- Provides boom angle needed to calculate radius
- Mounted in view of the cab



### Limit Switches

Limit switches are operational safety devices that prevent damage to the crane if a loss of control occurs. Most cranes are equipped with limit switches. The purpose of a hoist limit switch is to prevent over-travel of the hook block and the possibility of two-blocking. Two-blocking occurs when the hook block comes in contact with the upper sheave block during hoisting of the hook (or lowering the boom). Two-blocking is dangerous because it could result in damage to the crane, parting of the hoist lines, and dropping the load. These images are examples of weighted-type hoist upper-limit switches. A spring-loaded switch opens the circuit when the hook block raises the weight. Interruption of power to the hoist function stops the upward movement of the hoist block to prevent two-blocking.

**Operational Safety Devices: Limit Switches**



Weighted Type

---

---

### Over-Speed Operational Safety Devices

Over-speed, pressure, and temperature devices on crane-mounted engines are operational safety devices. When the engine provides the power to move loads, the devices provide shutdown ability to protect the engine from damage. Appendix F of the P-307 provides additional examples of operational safety devices.

---

---

---

**Operational Safety Devices**

Over-speed, pressure, and temperature devices are OSD's when:

- engine provides power to move loads
- they have shutdown capabilities



## Knowledge Check

- 6. Select the best answer.** What types of power does a category 1 or 4 crane generally use, and what is its source?
- A. Electric or hydraulic power supplied by a diesel engine.
  - B. Hydraulic and water power supplied by a compressor
  - C. Pneumatic and electric power supplied by a backup generator
  - D. Pneumatic and hydraulic power supplied by a compressor
- 7. Select the best answer to fill in the blank.** Load-\_\_\_\_\_ parts are those that restrain, position, or control the movement of the load.
- A. bearing
  - B. controlling
  - C. handling
  - D. lifting
  - E. operation
- 8. Select the best answer.** A hook is what type of component?
- A. General safety device
  - B. Load-bearing part
  - C. Load-controlling part
  - D. Operational safety device
- 9. Select the best answer.** Hydraulic foot brakes are what type of group of components?
- A. General safety devices
  - B. Load-bearing parts
  - C. Load-controlling parts
  - D. Operational safety devices
- 10. Select the best answer to fill in the blank.** Load-\_\_\_\_\_ parts are those that support the load.
- A. bearing
  - B. controlling
  - C. handling
  - D. lifting
  - E. operational
- 11. Select the best answer.** How is the electrical current conveyed from the revolving portion of the crane to the lower crane structure?
- A. through the collector ring system
  - B. through the electrical panels
  - C. through the main circuit board
  - D. through transistors

- 12. Select the best answer to fill in the blank.** Safety devices that provide protection for personnel and equipment are considered \_\_\_\_\_ safety devices.
- A. general
  - B. load-bearing
  - C. operational
  - D. universal
- 13. Select the best answer to fill in the blank.** Safety devices that affect the safe load lifting and handling capabilities of equipment are considered \_\_\_\_\_ safety devices.
- A. general
  - B. load-bearing
  - C. operational
  - D. universal
- 14. Select the best answer.** Which of the following does not affect the safe operation of the crane?
- A. General safety devices
  - B. Load-bearing parts
  - C. Load-controlling parts
  - D. Operational safety devices
- 15. Select the best answer.** A travel alarm is what type of group of components?
- A. general safety device
  - B. load-bearing part
  - C. load-controlling part
  - D. operational safety device

## OPERATOR'S DAILY CHECKLIST (ODCL)

### Welcome

Welcome to the Operator's Daily Checklist module.

---

---

---

### Learning Objectives

Upon successful completion of this module, you will be able to state the purpose of pre-operational checks, explain the frequency of pre-operational checks, and properly complete an Operator's Daily Checklist.

---

---

### Introduction

An Operators Daily Checklist or ODCL is a safety checklist. The ODCL aids the operator in doing a complete check and provides a record of daily inspections.

---

### Purpose

The daily inspection conducted by the operator is a general check by sight, sound, and touch. It helps the operator identify conditions that may render the crane unsafe to operate and enhances crane reliability.

---

---



**Welcome**

Welcome to the Operator's Daily Checklist module.

Begin

### Learning Objectives



Upon successful completion of this module, you will be able to:

- State the purpose of the Pre-Operational Daily Checks
- Explain the frequency of the Pre-Operational Daily Checks
- Properly complete an Operator's Daily Check List (ODCL)

### Introduction

Would you bet your life that your crane is up to its job?

An Operator's Daily Checklist (ODCL) is a safety checklist.

- aids the operator in doing a complete check
- provides a record of inspections

### Pre-Operational Check Purpose



- General check by:
  - Sight
  - Sound
  - Touch
- Identifies unsafe conditions
- Enhances crane reliability



### ODCL Frequency

A complete check of the crane is performed by the operator prior to the first use of the crane each day using a Crane Operator's Daily Checklist, referred to as the ODCL. The operator signs the ODCL at the completion of this initial check.

Subsequent operators review, perform operational checks, except boom limit switches, and sign the initial ODCL prior to operating the crane.

If a load is suspended from the hook for a period that spans more than one operator, the operator who completes the lift shall perform appropriate checks immediately upon completion of the lift, unless he or she will not operate the equipment again. For operations not involving a lift, such as moving the crane to a new location, the operator needs to check only the functions to be used. When a crane is used in construction, a complete pre-use check must be performed by each operator.

A documented pre-use check is not required for non-cab operated Category 3 cranes; however, for bridge, wall, and gantry cranes, a documented pre-use check shall be performed at least once each calendar month the crane is in use.

### ODCL Sections

A proper pre-operational check is performed in four sections: the walk around check, the machinery house or machinery area check, the operator's cab check, and the operational check.

The operator may perform the check from the various groupings in parallel.

---



---



---

### ODCL Frequency

- Complete check performed by the operator prior to first use each day
- Operator signs the ODCL at completion
- Subsequent operators:
  - review initial ODCL
  - perform operational checks, except boom limit switches
  - sign the initial ODCL
- When a crane is used in construction, a complete pre-use check must be performed by each operator
- A documented pre-use check is required at least once each calendar month for non-cab operated category 3 bridge, wall, and gantry cranes

---



---



---



---



---

### ODCL Sections

4 OPERATIONAL CHECK				S	U	NA
a	3 OPERATOR CAB CHECK			S	U	NA
b				S	U	NA
c	a	2 MACHINERY HOUSE CHECK		S	U	NA
d	b			S	U	NA
e	1 WALK AROUND CHECK			S	U	NA
f	a			S	U	NA
g	b			S	U	NA
h	c	a	Safety Guards and Plates *	✓		
i	d	b	Carrier Frame and Rotate Base *	✓		
j	e	c	General Hardware	✓		
k	f	d	Wire Rope *	✓		
l	g	e	Rec	✓		
o	h	f	Block	✓		
i	g	h	Hook	✓		
j	h	h	She	✓		
k	i	i	Block	✓		
l	j	j	Gan	✓		
m	k	k	Wall	✓		
l	l	l	Winch	✓		
m	m	m	Tires, Wheels and Tracks	✓		
n	n	n	Leaks	✓		
o	o	o	Outriggers and Stabilizers *	✓		
p	p	p	Load Chain *	✓		
q	q	q	Area Safety *	✓		

Within each section -  
Each area is marked:  
S = Satisfactory  
U = Unsatisfactory  
NA = Not Applicable

## Knowledge Check

- Select the best answer.** A complete check of the crane is performed by the operator prior to—
  - complex lifts only
  - moving the crane to a new location
  - securing the crane each day
  - the first use of the crane each day
- Select the best answer.** The ODCL is used to identify—
  - conditions that may render the crane unsafe
  - members of the current crane team
  - necessary and missing paperwork
  - who is licensed to operate the crane
- Select all that apply.** What are the four sections of a properly performed pre-operational check?
  - electrical function check
  - machinery house/machinery area check
  - operational check
  - operator's cab check
  - stability check
  - walk around check
- Select the best answer.** What method of inspection is used in the operator's daily check of the crane?
  - CCI Inspection
  - observing the crane in operation
  - review of the OEM manual
  - sight, sound, and touch

## Warning Tags

Before energizing the crane, look for warning tags. You may find warning tags posted with the certification card or information, attached on the pendant controller or other types of crane controls, or on the power source of the crane.

**Warning Tags**

During the crane inspection, you may find warning tag(s). If applied, these tags will generally be found:

- with the certification information
- on crane controls
- at a power source

**Warning:** Do not operate any crane which has evidence that a tag was on the crane such as a tie wrap, wire band, empty pouch, etc.



The red danger tag prohibits operation of equipment when its operation could jeopardize the safety of personnel or endanger equipment. If you discover one, never energize the crane with a danger tag attached! Energizing equipment with a danger tag attached may result in personnel injury or equipment damage.

---

---

---

---

The yellow caution tag generally gives some type of warning, precaution, or special instructions to the operator of the crane. Most caution tags inform of hazardous conditions such as rail stops, swing interference, crane clearance problems, etc. Always read and follow the written instructions on the tag before operating the crane. If you do not understand the instructions, ask your supervisor for clarification.

---

---

---

---

A Lockout Tag is installed to inform you that the energy has been locked out and is used to protect the person or persons who hung the tag while they are working on the affected system or component. It is intended for one shift use and is usually accompanied by a physical locking device to prevent operation.

---

---

---

---

Another tag you may find is an “Out of Service” tag. An Out of Service tag is normally installed to perform maintenance, testing, or inspection. When you find this tag, do not use or operate the crane.

---

---

Remember, only authorized personnel may install or remove warning tags.

### Tag Removal

Only authorized personnel may install or remove warning tags. Who are the authorized personnel? The person who applied the tag and sometimes his or her supervisor.

---

---

---



### Critical Components

The ODCL identifies components that are critical to the safe operation of the crane. Critical components are load-bearing parts, load-controlling parts, and operational safety devices. They are identified by an asterisk (\*) next to the item.

Any deficiency to a critical component or safety hazard must be reported to your supervisor immediately, and the crane shall not be operated until resolved.

---



---



---

Critical Crane Components										
1 WALK AROUND CHECK										
								S	U	NA
2 MACHINERY HOUSE CHECK										
								S	U	NA
3 OPERATOR CAB CHECK										
								S	U	NA
4 OPERATIONAL CHECK										
								S	U	NA
a Area Safety *										
b Outriggers and Stabilizers *										
c Unusual Noises										
e Wire Rope or Chain										
f Brakes and Clutches *										
g Boom Angle										
h Limit Switch										
i Emergency										
j Other Opera										
k General Saf										
l Fleeting She										

**\*Critical components:**

- Load bearing parts
- Load controlling parts
- Operational safety devices

### Limit Switches

Limit switches are operational safety devices that prevent damage to the crane if a loss of control occurs. Most cranes are equipped with limit switches. The purpose of a hoist limit switch is to prevent over-travel of the hook block and the possibility of two-blocking.

Two-blocking occurs when the hook block comes in contact with the upper sheave block during hoisting of the hook (or lowering the boom). Two-blocking is dangerous because it could result in damage to the crane, parting of the hoist lines, and dropping the load. These images are examples of weighted-type hoist upper-limit switches. A spring-loaded switch opens the circuit when the hook block raises the weight. Interruption of power to the hoist function stops the upward movement of the hoist block to prevent two-blocking.

---



---



---

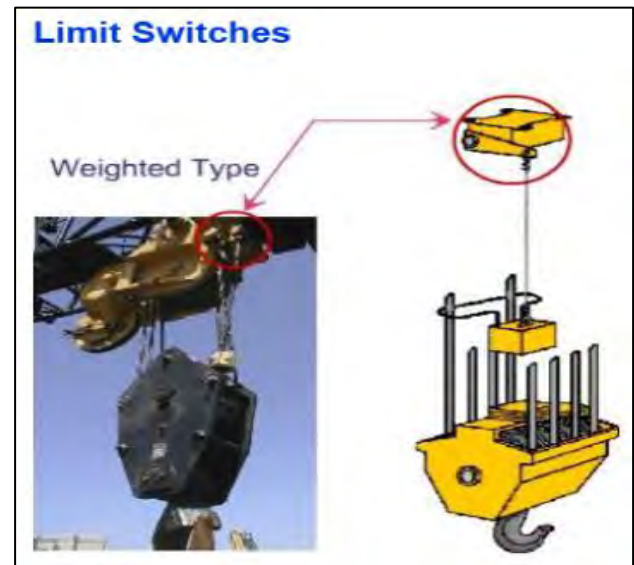

### Unsatisfactory Conditions

You must give a detailed description of unsatisfactory conditions in the remarks block of the ODCL form. If you discover a load bearing part, load controlling part or operational safety device that is unsatisfactory, you must stop, secure the crane and notify your supervisor. The supervisor shall immediately report the crane deficiency to the crane inspection organization. The item shall be marked by the operator as unsatisfactory on the ODCL and the deficiency shall be described in the remarks block. Minor deficiencies must be marked as unsatisfactory on the ODCL, and the operator shall describe the deficiency in the remarks block. The supervisor shall provide the ODCL to the organization responsible for corrective action.

---



---



---

### Recording

Results of the inspection must be noted on the Operator’s Daily Checklist or ODCL. Each item shall be marked “S” for satisfactory, “U” for unsatisfactory or “N/A” for not applicable. The operator signs the ODCL after performing the pre-operational check. The ODCL shall be turned in to the supervisor after the last use of the crane each day.

---



---



---

### Unsatisfactory Conditions

- Must be described in the “Remarks” block
- Take proper action for UNSAT items

**INSTRUCTIONS** – Check all applicable items indicated, prior to the first use each day. Suspend operations immediately upon observing an unsatisfactory condition of any item indicated with an asterisk (\*).

Operations may continue if the condition has been reviewed and continued operation has been authorized by the activity engineering organization.

For any unsatisfactory item, identify the specific components and describe the deficiency in the “Remarks” block.

**REMARKS**

Bridge lights not working

### Recording



1) Mark each item:

- S = Sat
- U = Unsat
- NA = Not Applicable

2) Sign Card

3) Turn in Daily

## Knowledge Check

5. **Select the best answer.** On the ODCL, critical crane components are identified by—
- A. ampersand (&)
  - B. asterisks (\*)
  - C. bold letters
  - D. letter color: red for critical, yellow for cautionary
6. **Select the best answer.** Critical components must be carefully examined during the ODCL. Which of the follow is (are) considered critical components?
- A. batteries
  - B. emergency stop button
  - C. windlocks, stops, and bumpers
7. **Select the best answer.** If you discover a load bearing part, load controlling part, or operational safety device that is unsatisfactory, you should—
- A. report the situation to crane inspection
  - B. report the situation to crane maintenance
  - C. resolve the situation before continuing
  - D. stop, secure the crane, and notify your supervisor
8. **Select the best answer.** Whether a critical component or not, any unsatisfactory conditions must be—
- A. delivered to maintenance and engineering for action
  - B. described in the “Remarks” block of the ODCL
9. **Select the best answer.** Each item on the ODCL shall be marked—
- A. correct, incorrect, not applicable
  - B. satisfactory, unsatisfactory, or not applicable
  - C. serviceable, unserviceable, or not applicable
  - D. stable, unstable, or not applicable
10. **Select the best answer.** What is the purpose of a hoist upper limit switch?
- A. to cause the operator to slow down
  - B. to cut off power to the crane when contacted
  - C. to prevent overtravel of the hook block and the possibility of two-blocking
  - D. to prevent rotation of the hook

### Walk Around Check

This is a sample walk around check section from an ODCL. Begin this check by walking around the crane and job site observing anything that is out of order or out of place as well as any potential hazards or interference.

---



---



---

**Walk Around Check**

1 WALK AROUND CHECK			
	S	U	NA
a			
b			
c			
d			
e			
f			
g			
h			
i			
j			
k			
l			
m			
n			
o			
p			
q			



### Safety Guards and Plates

Check for missing safety guards and plates.

---



---



---

**Safety Guards and Plates**



- Check for missing or damaged safety guards and plates

### Carrier Frame and Rotate Base

Check the carrier frame and rotate base thoroughly for obvious physical damage such as cracking, bending, or deformation of plates or welds. Check for cracking or flaking of paint that may indicate a crack or damage in the structure beneath. Check hook rollers, bull gear, and the rotate pinion.

---



---



---

**Carrier Frame and Rotate Base**



- Check for cracking, bending, or deformation of plates or welds
- Check for cracking or flaking of paint
- Check hook rollers, bull gear, and the rotate pinion

### General Hardware

As you walk around the crane, look for missing and loose hardware such as nuts, bolts, brackets, and fittings.

---



---



---

**General Hardware**



- Check for missing or loose nuts, bolts, brackets, and fittings

### Wire Rope and Reeving

Visually check wire rope for unusual wear, fraying, birdcaging, corrosion, and kinking. Check end connections, where visible, for proper configuration, seating, and condition of wire rope.

Visually check the condition of wire rope or load chain reeving. Ensure wire rope or load chain is running true in the hook block and boom point sheaves, and laying correctly on the drum or sprockets.

---

---

---

### Block and Hook

Visually check the condition of the block and ensure all swivels rotate freely.

Check the condition of the hook for cracks, excessive throat opening, or twist. If rigging gear is on the hook and cannot be easily removed, check the hook to the maximum extent possible without removing rigging gear.

---

---

---

### Sheaves or Sprockets

Check, where practical, the condition of sheaves or sprockets to determine that they are free to rotate and are not cracked or chipped.

---

---

---

#### Wire Rope and Reeving

Visually check wire rope for:

- Unusual wear, fraying, birdcaging, corrosion, and kinking
- Check end connections for proper configuration, seating, and condition

Visually check wire rope or load chain reeving

- Ensure wire rope or load chain is running true in the hook block and boom point sheaves, and laying correctly on the drum or sprockets



#### Block and Hook

- Check the condition of the block and ensure all swivels rotate freely
- Check the hook for cracks, excessive throat opening, or twist



#### Sheaves or Sprockets



- Check the condition of sheaves or sprockets to determine that they are free to rotate and are not cracked or chipped.



### Boom and Jib

Check the condition of the boom and jib for straightness and any evidence of physical damage, such as cracking, bending, or other deformation of the steel elements or welds.

When checking lattice booms, be especially watchful for bent lattices and dents in the main chords. It is important to have bent or dented crane boom members inspected and evaluated because they can greatly reduce the strength of a boom, possibly resulting in a sudden collapse of the boom.

**Boom and Jib**

- Check the condition of the boom and jib to determine:
  - straightness
  - evidence of physical damage
  - cracking
  - bending
  - deformation of the steel elements or welds



---

---

### Gantry, Pendants, and Boom Stops

Check the condition of the gantry, pendants, and boom stops. Check the gantry for distortion or other damage. Check boom pendants for sags, unequal length, and that the anchor pins are set. Check boom stops to ensure they are not damaged and telescoping struts are not jammed.

**Gantry, Pendants, and Boom Stops**

- Check the gantry for distortion or other damage
- Check boom pendants for sags, unequal length, and that the anchor pins are set
- Check boom stops to ensure they are not damaged, and telescoping struts are not jammed



---

---

---

### Walkways, Ladders, Handrails

Check the condition of walkways, ladders, and handrails for loose mountings, cracks, excessive rust, loose rungs, or any other signs of unsafe conditions. Ensure safety chains and gates are functional.

**Walkways, Ladders, Handrails**

- Check walkways, ladders, and handrails for:
  - loose mountings
  - cracks
  - excessive rust
  - loose rungs
  - unsafe conditions



---

---

---

### Wind locks, Stops, and Bumpers

Check for free action of wind locks. Check stops and bumpers on the crane for cracks or other damage.

---

---

---

#### Windlocks, Stops, and Bumpers

- Check for free action of windlocks
- Check stops and bumpers for cracks or other damage



### Tires, Wheels, and Tracks

Check the condition of tires for inflation, serious cuts, or excessive wear. If lifts on rubber are planned, check tires with a gauge for proper inflation pressure per Original Equipment Manufacturer or OEM load charts.

Check wheels to ensure they are not loose or damaged. On track machines, look for excessive slack, broken or loose pads, or any other obvious defects.

---

---

---

#### Tires, Wheels, and Tracks

- Check tire condition for:
  - proper inflation
  - serious cuts
  - excessive wear
- Check wheels to ensure they are not loose or damaged.
- Check tracks for broken or loose pads or any other obvious defects.



### Leaks

Check for evidence on the crane and on the ground beneath the crane, of any leakage of fuel, lubricating oil, hydraulic fluid, or engine coolant.

---

---

---

#### Leaks

- Check on the crane and on the ground for evidence of any leakage of:
  - fuel
  - lubricating oil
  - hydraulic fluid
  - engine coolant



### Outriggers and Stabilizers

Check outriggers and stabilizers for damage. If floats or pads are not permanently installed on the outriggers, ensure they are on the carrier and that they are not damaged.

---

---

---

### Load Chain

Check for damaged or deteriorated links.

---

---

---

### Area Safety

Check the work area and ensure that the exact locations of obstacles or hazards are known. Ensure ground conditions are sufficiently firm to support a loaded crane. Verify temporary connections are removed or cleared for operation (e.g., temporary shore power or hotel power).

---

---

---

#### Outriggers and Stabilizers



- Check outriggers and stabilizers for damage.

#### Load Chain

- Check for damaged or deteriorated links



#### Area Safety



- Check the work area for:
  - exact location of obstacles or hazards
  - adequate ground loading
- Verify temporary connections such as shore power are removed or cleared for operation.

### Machinery House / Machinery Area Check

This graphic represents the machinery check section of a typical ODCL. The operator shall perform a machinery house/machinery area check on those cranes and trolleys equipped with a safe access means.

For category 2 and 3 cab-operated cranes, the machinery area check shall be from the ground, the operator’s cab, and the walkways.

---



---



---

**Machinery House/Machinery Area Check**

2 MACHINERY HOUSE CHECK			
	S	U	NA
a Housekeeping	✓		
b Diesel Engine and Generator *	✓		
c Leaks			
d Lubrication			
e Battery			
f Lights			
g Glass			
h Clutches and Brakes *			
i Electric Motors *			
j Auxiliary Engine and Compressor			
k Danger/Caution Tags *			
l Fire Extinguishers			
m Hoist Drum Pawls and Ratchets *			



### Housekeeping

Check to ensure that the machinery house or machinery area and accesses are clean. The crane operator is responsible for the cleanliness and housekeeping of the crane. Ensure tools and authorized materials are properly stored and that waste and debris are removed.

---



---



---

**Housekeeping**

- Ensure that the machinery house/area and accesses are clean and free of materials
- Store tools and materials properly
- Remove waste and debris



### Diesel Engine and Generator

Check the diesel engine lube oil level, radiator coolant level, hydraulic oil level, and fuel level. Check fan and drive belts for damage. Check for evidence of loose fasteners, oil or grease splashes, and any indications of overheating.

---



---



---

**Diesel Engine and Generator**

- Check the diesel engine for proper:
  - lube oil level
  - radiator coolant level
  - hydraulic oil level
  - fuel level
- Check fan and drive belts for damage.
- Check for evidence of:
  - loose fasteners
  - oil or grease splashes
  - overheating



### Leaks

Inspect for excessive grease on machinery. Look for hydraulic brake fluid leaks around brake linings and cylinders. Check for lubricating oil leaks around gear cases. If there appears to be more than normal seepage, report the condition to your supervisor.

---

---

### Lubrication

Check gear cases for lubricant level and evidence of over or under lubrication of crane components.

---

---

---

### Battery, Lights, and Glass

Check the battery for excessive corrosion and leakage. Check to ensure machinery house lights are working. Check for broken or missing glass in machinery house doors or windows.

---

---

### Clutches and Brakes

Check accessible portions of clutches and brakes for evidence of excessive heat, wear, or grease and oil on the linings. Check for evidence of loose fasteners and for missing or broken parts. If a brake is equipped with a manual release mechanism, check to ensure the mechanism is not in the released position.

---

---

---

#### Leaks

- Check for leaks of:
  - Lubricating oil
  - Fuel
  - Coolant
  - Hydraulic oil
  - Grease



#### Lubrication

- Check gear cases for lubricant level.
- Look for signs of:
  - Inadequate lubrication
  - Excessive lubrication



#### Battery, Lights, and Glass



- Check the batteries for excessive corrosion and leakage
- Check machinery house lighting
- Check for broken or missing glass

#### Clutches and Brakes

- Check clutches and brakes for evidence of:
  - excessive heat
  - wear
  - grease and oil on the linings
  - loose fasteners
  - missing or broken parts



### Electric Motors

Check all motors for evidence of loose fasteners, oil or grease splashes, and any indications of overheating.

---

---

---

#### Electric Motors



- Inspect motors for evidence of:
  - loose fasteners
  - oil or grease splashes
  - indications of overheating

### Auxiliary Engine and Compressor

Check lube oil level, radiator coolant level, hydraulic oil level, and fuel level. Check fan and drive belts for damage. Check for evidence of loose fasteners, oil or grease splashes, and any indication of overheating.

---

---

---

#### Auxiliary Engine and Compressor

- Check the following on the auxiliary engine and compressor:
  - lube oil level
  - radiator coolant level
  - hydraulic oil level
  - fuel level
  - fan and drive belts for damage
  - loose fasteners
  - oil or grease splashes
  - indication of overheating



### Danger/Caution Tags

If danger or caution tags are posted, read, understand, and follow the directions on the tags.

Check the appropriate ODCL column as follows: “S” – all tags are properly hung; “U” – tags improperly hung or otherwise deficient; “NA” – no tags.

---

---

---

#### Danger/Caution Tags

If danger or caution tags are posted, read, understand, and follow the directions on the tags.

Check the appropriate ODCL column with:

- “S” - All tags are properly hung
- “U” - Tags improperly hung or deficient
- “NA” - No tags



### Fire Extinguishers

Ensure fire extinguishers are in place, seals are unbroken, and inspection tags are up to date.

---

---

---

#### Fire Extinguishers

- Ensure fire extinguishers are in place, seals are unbroken, and inspection tags are up to date.



### Hoist Drum Pawls and Ratchets

Check locking pawls and ratchets, where visible, for damage, alignment, and proper engagement.

---



---



---

#### Hoist Drum Pawls and Ratchets

- Check locking pawls and ratchets for:
  - damage
  - alignment
  - proper engagement



### Knowledge Check

**11. Select the best answer.** Discoloration of the brake drum is usually caused by—

- A. lubrication
- B. normal operations
- C. overheating
- D. overloading the crane

**12. Select the best answer.** During inspection, cracked or flaking paint may indicate—

- A. aluminum paint on steel components
- B. latex paint over alkyd primer
- C. poor quality paint
- D. structural damage or loose bolts

### Operator Cab Check

This is a typical Operator's Cab Check section from an ODCL. The operator should enter the cab and ensure all controls are in the neutral or off position prior to starting the engine. Start the engine and check the items in the Operator Cab Check section. Operators shall not carry articles in their hands or carry large articles in their pockets when climbing ladders to access the cranes.

---



---



---

#### Operator's Cab Check

3 OPERATOR CAB CHECK			
	S	U	NA
a Gauges		✓	
b Indicator and Warning Lights	✓		
c Visibility *	✓		
d Load Rating Charts *	✓		
e List/Trim Indicator (Floating Cranes) *			
f Boom Angle/Radius Indicator *			
g Fire Extinguisher			
h Level Indicator (Mobile Cranes) *			
i Danger/Caution Tags *			



### Gauges, Indicator and Warning Lights

Check gauges to ensure none are broken or missing and that they are operating normally.

Check indicator and warning lights to ensure none are broken or missing and that applicable indicator and warning lights are lit.

---



---



---

### Gauges, Indicator, and Warning Lights

- Check gauges to ensure none are broken or missing, and that they are operating normally
- Check indicator and warning lights to ensure none are broken or missing and that applicable indicator and warning lights are lit



### Visibility

Check visibility to ensure that all windows and mirrors are clean, unbroken, and that any vandal guards have been removed from windows.

---



---



---

### Visibility

- Check to ensure windows and mirrors are clean and unbroken



### Load Rating Charts

Ensure that the load rating charts are posted in the operator's cab and that they are legible.

Verify that the crane number is correct, the certification expiration date is not expired, and the crane capacity is listed.

The two expiration dates that are of particular importance to all crane operators are the expiration date of the certification of the crane being operated, and the expiration date of the operator's license. The operator cannot operate a crane if his or her license is expired, and a crane may not be operated to perform production lifts if the crane certification is expired.

---



---



---

### Load Rating Charts

SE 1100 Tower Crane  
as Designed July 2008/2007

Lift Height (ft)	Basic Capacity (kg)				Basic Capacity (lb)			
	100'	120'	140'	160'	220'	280'	340'	400'
100'	10,000	8,000	6,000	4,000	22,000	17,600	13,200	8,800
120'	8,000	6,000	4,000	2,000	17,600	13,200	8,800	4,400
140'	6,000	4,000	2,000	1,000	13,200	8,800	4,400	2,200
160'	4,000	2,000	1,000	500	8,800	4,400	2,200	1,100
180'	2,000	1,000	500	250	4,400	2,200	1,100	550
200'	1,000	500	250	125	2,200	1,100	550	275
220'	500	250	125	62	1,100	550	275	137
240'	250	125	62	31	550	275	137	68
260'	125	62	31	16	275	137	68	34
280'	62	31	16	8	137	68	34	17
300'	31	16	8	4	68	34	17	8
320'	16	8	4	2	34	17	8	4
340'	8	4	2	1	17	8	4	2
360'	4	2	1	0.5	8	4	2	1
380'	2	1	0.5	0.25	4	2	1	0.5
400'	1	0.5	0.25	0.125	2	1	0.5	0.25

Ensure that load rating charts are posted in the operator's cab.

Verify the following:

- The crane number is correct.
- The certification expiration date is not expired.
- Crane capacity is listed.



### List and Trim Indicator

On floating cranes, check list and trim indicators to ensure the crane is level within tolerances.

Ensure both list and trim bubble tubes are in their respective holders and not broken.

---

---

---

### Boom Angle/Radius Indicator

Check indicators for damage and ensure linkages are connected. When electronic indicators are used, ensure power is supplied.

---

---

---

### Fire Extinguishers

Ensure fire extinguishers are in place, seals are unbroken, and inspection tags are up to date. Operators shall be familiar with the location, operation, and care of fire extinguishers provided.

---

---

---

### Level Indicator

On mobile cranes, check the level indicator for damage.

---

---

---

#### List and Trim Indicator

- On floating cranes, check list and trim indicators to ensure the crane is level within tolerances.



#### Boom Angle / Radius Indicator



- Check indicator(s) for damage
- Ensure linkages are connected

#### Fire Extinguishers

Ensure fire extinguishers are in place, seals are unbroken, and inspection tags are up to date.



#### Level Indicator



- Check the level indicator for damage.

### Danger/Caution Tags

If danger or caution tags are posted, read, understand, and follow the directions on the tags. Check the appropriate ODCL column as follows: “S” – all tags are properly hung; “U” – tags improperly hung or otherwise deficient; “NA” – no tags.

---

---

---

### Instructions

Check to ensure all required instructions are available in the cab. Required instructions may include operating instructions, Original Equipment Manufacturer or OEM operations manual, adverse weather operating instructions, and additional activity specific instructions.

---

---

---

### Housekeeping

Check to ensure the operator's cab is free of clutter and unnecessary clothing, and that personal belongings, tools, maintenance products, waste, etc., are properly stored and not be permitted to lie loose about the cab or interfere with operation.

---

---

---

#### Danger/Caution Tags

- If danger or caution tags are posted, read, understand, and follow the directions on the tags.
- Check the appropriate ODCL column with:
  - “S” - All tags are properly hung
  - “U” - Tags improperly hung or deficient
  - “NA” - No tags



#### Instructions

- Ensure all required instructions are in the cab.
- Required instructions may include:
  - Operating instructions
  - Operation manual
  - Adverse weather operating instructions
  - Activity specific instructions



#### Housekeeping

- Ensure the cab is free of clutter and unnecessary clothing
- Personal belongings, tools, maintenance products, and waste should be properly stored



### Operational Check

The final check before placing the crane in service is the operational check. The operational check shall include operating the machine without load through all motions, using all controls through a range sufficient to ensure their proper operation, and verifying the proper operation of safety devices, gauges, meters, warning signals, limit switches, and other devices. When possible, the operational check shall be conducted away from personnel and any hazardous surroundings. A qualified rigger, if present during the operational check, should control access, observe crane operation, and report any unusual noises or other indications of unsafe conditions to the crane operator.

When performing the operational check portion of the ODCL in cold weather or icy conditions, the operator should raise the blocks and boom before lowering them to avoid damage when sheaves may be frozen.

Operators should inform rigging personnel to stand clear of the area below the blocks and boom prior to operation.

The operator should hoist up slowly, in small increments, to break any ice and/or snow free, and monitor the sheaves to ensure proper movement and operation of the sheaves and wire rope.

### Area Safety

Check the work area and ensure that the exact locations of obstacles or hazards are known. Ensure ground conditions are sufficiently firm to support a loaded crane. It is not expected that all possible areas of travel be checked during the pre-use check. However, before any area of travel is utilized that has not been checked during the pre-use check additional attention should be focused on obstacles and potential hazards.

---



---



---

4 OPERATIONAL CHECK			
	S	U	NA
a Area Safety *	✓		
b Outriggers and Stabilizers *	✓		
c Unusual Noises			
d Control Action *			
e Wire Rope or Chain *			
f Brakes and Clutches *			
g Boom Angle / Radius Indicator *			
h Limit Switches *			
i Emergency Stop *			
j Other Operational Safety Devices *			
k General Safety Devices			
l Fleeting Sheaves			



---



---



---



---



---



---



---



---



---



---

**Area Safety**

Check the work area for:

- exact location of obstacles or hazards
- adequate ground loading



### Outriggers and Stabilizers

Prior to initial set up, check outriggers and stabilizers to ensure they function freely.

---

---

---

#### Outriggers and Stabilizers



Prior to set up, check outriggers and stabilizers to ensure they function freely.

### Unusual Noises

After starting the engine, be alert for unusual noises, fluid leaks, improper functioning, incorrect readings of gauges, and loss of power or bad response to control of the engine or motors.

---

---

---

#### Unusual Noises

After starting the engine, be alert for:

- unusual noises
- fluid leaks
- improper functioning
- incorrect readings of gauges
- loss of power



### Controls and Control Action

Check control mechanisms for excessive wear of components and contamination by lubricants or other foreign material. Check controls through a range sufficient to ensure that they operate freely, and that the corresponding component actuates properly when controls are activated. Check hoist controls through the full speed range.

---

---

---

#### Controls and Control Action



Check controls to ensure they:

- operate freely
- actuate properly

Check hoist controls through the full speed range.

### Wire Rope or Chain

Check for proper paying-out of the wire rope or chain, that the wire rope or chain and hook blocks do not twist or spin, and that the wire rope or chain is running freely through the sheaves or sprockets and blocks.

If the boom and hoist drums or load sprocket are visible from the operator's station, check for proper spooling of the wire rope on and off the drum or chain on and off the load sprocket. After lowering the hooks and the boom for limit switch tests and hook inspections, observe sections of wire rope or chain that may not be visible during the walk around check.

#### Wire Rope or Chain

Check wire rope or chain to ensure there is:

- proper paying-out
- no twisting or spinning of hook blocks
- wire rope or chain running freely through the sheaves, sprockets, or blocks
- proper spooling or reeving on the drums (if visible)



---

---

---

### Brakes and Clutches

Check brake and clutch actions and ensure they are functioning normally and that there is no slippage, excessive play, or binding. Exercise brakes and clutches to ensure they are dry.

#### Brakes and Clutches

Check brake and clutch actions to ensure there is no:

- slippage
- excessive play
- binding

Exercise brakes and clutches to ensure they are dry.



---

---

---

### Boom Angle/Radius Indicator

Check operation of the boom angle and/or radius indicator.

#### Boom Angle / Radius Indicator

- Check operation of the boom angle and/or radius indicator.



---

---

---



### Emergency Stop

Check the emergency stop or power-off button. Know its location and ensure it is working properly. If the emergency stop is checked while a motion is in operation, check at the slowest possible speed.

Note: This is not applicable to diesel engine shutdowns on portal and floating cranes.

---

---

---

#### Emergency Stop

- Know its location
- Ensure it works properly
- If checked while a motion is in operation, check at the slowest speed possible



### Other Operational Safety Devices

Check any other operational safety devices as directed by the activity engineering organization. An example would be dead-man controls. Dead-man controls are controllers that automatically stop operations when released. These pictures show two types of dead-man controls: a foot switch, and a push-button thumb switch on top of the controller.

---

---

---

#### Other Operational Safety Devices



- Check operation of any other operational safety devices such as dead man controls or switches
- **Note:** Dead man controls refer to controllers that automatically stop operations when released.

### General Safety Devices

Check general safety devices such as sirens, horns, and travel alarms for proper operation.

---

---

---

#### General Safety Devices

- Check sirens, horns, and travel alarms for proper operation



### Fleeting Sheaves

Check operation of fleeting sheaves, where visible, to ensure they travel freely on the shaft. A fleeting sheave is a sheave that moves along its supporting shaft or pin. The fleet angle is the angle formed by the lead of a rope at the extreme end of a drum with a line drawn perpendicular to the axis of the drum through the center of the nearest fixed sheave.

---

---

---

**Fleeting Sheaves**

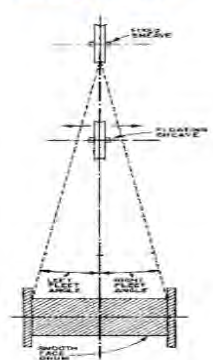

- Check fleeting sheaves where visible
- Ensure proper operation

### Summary

Performing a thorough and complete pre-operational crane check is the first step toward safe and reliable crane operations.

The ODCL identifies unsafe conditions and enhances crane reliability. It verifies proper operation of the crane and is conducted once each day.

The ODCL is reviewed by subsequent operators. The operational check is required once per shift.

The ODCL is separated into four sections: the walk around check, machinery house or machinery area check, operator's cab check, and the operational check.

---

---

**ODCL Summary**

**Purpose**

- General check
- Identifies unsafe conditions
- Enhances crane reliability

**Importance**

- Verifies operation of the crane

**Frequency**

- Once each day
- Verification by each operator

**Sections of the ODCL**

- Walk Around Check
- Machinery House/Machinery Area Check
- Operator's Cab Check
- Operational Check





### Knowledge Check

- 13. Select the best answer.** The crane number, certification expiration date, and certified capacity are found—
- A. In the EOM
  - B. In the load lift review
  - C. In the operator’s manual
  - D. Posted in the crane maintenance area
  - E. Posted on the crane
- 14. Select the best answer.** Dead man controls refer to controllers that automatically—
- A. Change operational speeds to suit conditions.
  - B. Compensate for slow operator response.
  - C. Push your hand away from the handle when the crane stops.
  - D. Stop operations when released.
- 15. Select the best answer.** If you observe a red tag on a piece of equipment, you should—
- A. Fix the problem and operate the equipment.
  - B. Remove the tag and continue operations.
  - C. Review the special instructions and operate accordingly.
  - D. Under no circumstances operate this piece of equipment.
  - E. Verify the tag was from previous work.
- 16. Select the best answer.** If you observe a yellow tag on a piece of equipment, you should—
- A. Fix the problem and operate the equipment.
  - B. Remove the tag and continue operations.
  - C. Review the special instructions and operate accordingly.
  - D. Under no circumstances operate this piece of equipment.
  - E. Verify the tag was from previous work.

### Completion

---

---

---

<p><b>Completion</b></p> <p><b>Congratulations.</b></p> <p>You have completed the General Crane Safety's Operator's Daily Checklist module.</p> <p>Click on the Exit button to return to the main module menu.</p>
--

## DETERMINING LOAD WEIGHT

### Welcome

Welcome to Determining Load Weight.

---

---

---

### Learning Objectives

Upon successful completion of this module, you will be able to identify the importance of knowing the weight of an item, choose acceptable ways to obtain weight information, calculate area and volume of basic objects, and determine the weight of basic shapes.

---

---

### Load Weight

Load weight determines the capacity of the crane and the rigging gear required.

If the weight is estimated to exceed 50% of the capacity of the hoist or 80% of the capacity of the rigging gear, platform/skid, below-the-hook lifting device, etc., the weight shall be verified by performing an engineering evaluation or using a local procedure approved by the certifying official or activity engineering organization. Alternatively, a load-indicating device shall be used.



### Learning Objectives

Upon successful completion of this module, you will be able to:

- Identify the importance of knowing the weight of an item
- Choose acceptable ways to obtain weight information
- Calculate area and volume of basic objects
- Determine the weight of basic shapes

### Load Weight Determines

- Capacity of the crane required
- Capacity of the rigging gear required

**You must know the load weight!**

---

---

---

### Determining Load Weight: Acceptable Methods

Load-indicating devices, label plates, documentation, engineering evaluation, and calculation are all acceptable methods of determining load weight. When using a load-indicating device (LID) to determine load weight, the rigger-in-charge shall have a reasonable estimate of the weight to be lifted. An appropriate stop point shall be established, and the load indicating device shall be carefully monitored to ensure the stop point is not exceeded.

---

---

---

### Determining Weight: Unacceptable Methods

Never take word of mouth to establish load weight! Word of mouth may be used as a starting point for sizing the crane and rigging gear so the component can be weighed with a load indicating device, but never shall it be used as the final determination of load weight.

To avoid overloading any equipment used in a crane lift, the rigger-in-charge shall know or have a reasonable estimate of the weight to be lifted. If the weight is estimated to exceed 50% of the capacity of the hoist or 80% of the capacity of the rigging gear, platform/skid, below-the-hook lifting device, etc., the weight shall be verified by performing an engineering evaluation or using a local procedure approved by the certifying official or activity engineering organization. Alternatively, a load indicating device shall be used.

### Determining Weight: Guidelines

When determining the weight of an object, you can always round up the dimensions and the weight, but never round down. Never mix feet and inches and double-check your answers.

---

---

### Acceptable Methods of Determining Load Weight

- Load-indicating device
- Label plates
- Documentation
- Engineering evaluation
- Approved calculations



### Unacceptable Methods

**Never accept word of mouth to establish weight!**

---

---

---

---

---

---

### Guidelines for Determining Weight

- Round up on the dimensions
- Never mix feet and inches
- Round up on the weight
- Double check your answers

### Standard Weights

This is a standard chart showing the weights of various materials per square foot, per inch of thickness and weight per cubic foot of volume. This chart is used as an aid when calculating load weights.

---



---



---

**Standard Weights of Materials**

Material	Weight cubic	Material	Weight per sq foot per inch of thickness
Ash	42	Aluminum	14.5
Birch	47	Brass	44.5
Cedar	34	Bronze	46.2
Cherry	36	Copper	46.5
Fir	34	Iron	41.1
Hemlock	29	Lead	59.2
Maple	53	Monel	46.3
Oak	50	Nickel	44.5
Pine (white)	25	Silver	54.7
Reinforced Concrete	150	Steel	40.8
Sand	125	Steel (stainless)	41.8
Steel	490	Tin	36.3
Aluminum	165	Zinc	36.7
Brass	543		

### Finding Weight

Weights may be calculated using either area or volume. Find the weight of objects such as plates by multiplying the area in square feet by the material weight per square foot for a given thickness. To find the weight of three-dimensional objects, multiply volume in cubic feet by the material weight per cubic foot. Which calculating method you use, will depend on the item. You may need to use both methods for complex objects.

---



---



---

**Calculating the Weight by Area or Volume**

- **Using Area**
  - area in square feet multiplied by material weight per square foot for a specific thickness
- **Using Volume**
  - volume in cubic feet multiplied by material weight per cubic foot

### Calculating Weight by Area

To calculate the weight of this plate, we must find the area and multiply it by the material weight per square foot. Here, we have a steel plate, 4 feet by 2 feet by 1 inch thick. The area is 8 square feet. To calculate the weight, we need to find the unit weight or weight per square foot for the material. Using the standard material weight chart, we find steel weighs 40.8 pounds per square foot per inch of thickness. The math can be simplified by rounding to 41 pounds. Multiplying 8 square feet by 41 pounds per square foot gives us 328 pounds.

---



---



---

**Calculating Weight by Area**



- 1" thick steel weighs 40.8 lbs. per square foot
- Area = 8 sq. ft.

Area x Unit weight per sq. foot = weight

8 sq. ft.  
 x 41 lbs per sq. ft. (rounded)  
 328 lbs.

### Calculating Weight by Volume

Volume is always expressed in cubic units such as cubic inches, cubic feet, and cubic yards. Let's calculate the volume of this box. The formula is length, times width, times height. The length is 12 feet. The width is 10 feet. The height is 4 feet. When we multiply 12 times 10 times 4, the volume is 480 cubic feet. Now we can use the standard materials weight chart and multiply the standard weight by the volume.

---

---

---

**Calculating Weight by Volume**

Volume = Length x Width x Height      Steel weighs 490 lbs. per cubic foot  
 $12' \times 10' \times 4' = 480$  cubic feet       $490 \times 480 = 235,200$  lbs.



### Calculating Area

The area of a square or rectangular shaped object is determined by multiplying length times width or base times height. The area is always expressed in units of square feet or square inches.

---

---

---

**Calculating Area**

Area = Length x Width

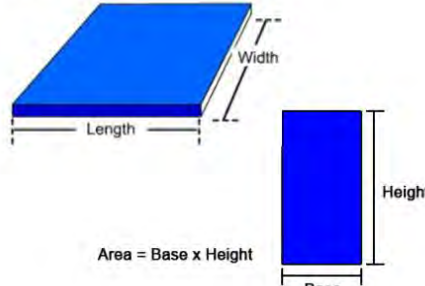

Area = Base x Height

### Calculating the Area of a Triangle

To calculate the area of a triangle, multiply the base of the triangle by the height of the triangle and then divide by 2.

The height of a triangle is the perpendicular distance from the point opposite from the base to the base.

---

---

---

**Calculating the Area of a Triangle**

Area =  $\frac{\text{Base} \times \text{Height}}{2}$

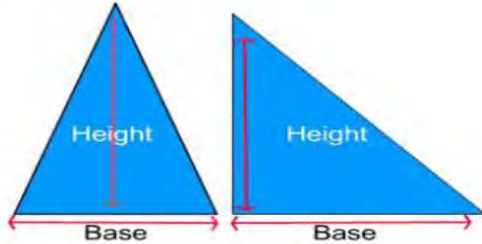

### Calculating the Area of a Circle

To calculate the area of a circle, multiply Pi, which is 3.14, by the radius squared. Find the radius of the circle by dividing its diameter in half. To square the radius, multiply the radius by itself. For example, if a circle has a diameter of 3 feet, the radius will be 1.5 feet. 1.5 feet times 1.5 feet equals 2.25 square feet. Therefore, the radius squared is 2.25 square feet. Pi times the radius squared would be 3.14 times 2.25 square feet, or 7.065 square feet.

---



---



---

**Calculating the Area of a Circle**

Area =  $\pi \times \text{Radius}^2$   
 $\pi$  (Pi) = 3.14  
 Radius<sup>2</sup> = Radius x Radius

### Calculating the Area of a Complex Shape

Most complex shapes can be broken down into a series of simple shapes. To calculate the area of this complex shape, calculate the area of the square using the formula length times width. Next, calculate the area of the triangle using the formula base times the height divided by 2. Then, add the areas together to get the total area of the complex shape.

---



---



---

**Calculating the Area of a Complex Shape**

Area = L x W

$\frac{B \times H}{2} = \text{Area}$

### Area of First Part

The first step is to calculate the area of the rectangle or square as shown in this example. The formula for the area of a rectangle is, length times width. The length is 8 feet and the width is 8 feet. 8 feet, times 8 feet, equals 64 square feet.

---



---



---

**Calculating the Area of the First Part**

Area = Length x Width  
 $8' \times 8' = 64 \text{ sq feet}$

**Area of Second Part**

Next, find the area of the triangle. The formula for the area of a triangle is, base times height divided by 2. The base is 4 feet and the height is 8 feet. 4 feet times 8 feet equals 32 ft<sup>2</sup>. 32 ft<sup>2</sup> divided by 2 equals 16 ft<sup>2</sup>.

---



---



---

**Calculating the Area of the Second Part**

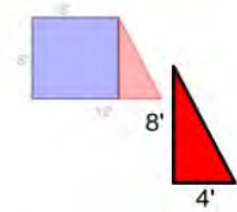

Area of a Triangle =  $\frac{\text{Base} \times \text{Height}}{2}$

$$\frac{8' \times 4'}{2} = 16 \text{ sq ft}$$

**Adding Areas**

Now that we have found the area of the two sections, all we have to do is add the area of the square to the area of the triangle to find the total area of the object. 64 square feet, plus 16 square feet, equals 80 square feet. If we know what the material is and how thick it is, we can find its weight with one more calculation.

---



---



---

**Calculating the Area - Complex Shapes**

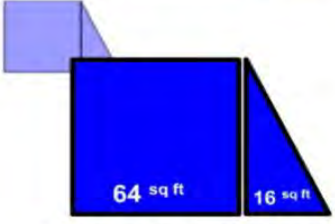

64 sq ft + 16 sq ft = 80 sq ft Total Area

**Calculating Area and Materials Weight – Step One**

To calculate the weight using area, we must find the material weight per square foot based on its thickness. Then, we simply multiply the base weight by the area of material. The area of this steel plate is 80 square feet.

---



---



---

**Calculating Material Weight**



Length x Width = Area  
10' x 8' = 80sq ft

Length = 10'

Width = 8'

### Calculating Area and Materials Weight – Step 2

Now we need to know the plate's thickness. According to the ruler, it is 1 inch thick.

---



---



---

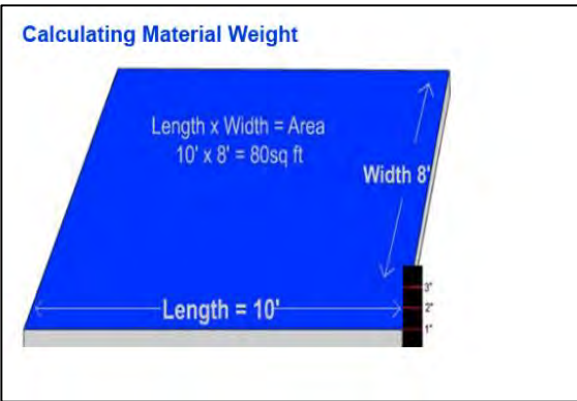

### Calculating Area and Materials Weight – Step 3

We can find the weight of common materials listed in several reference books available from various industry sources. Here, in *Ace's Book of Rigging*, we find these tables. Material weight per cubic foot is in the left table. In the right table, unit weights are listed by weight per square foot, per inch of material thickness. We will use the table on the right since the material weights here are based on the thickness of material.

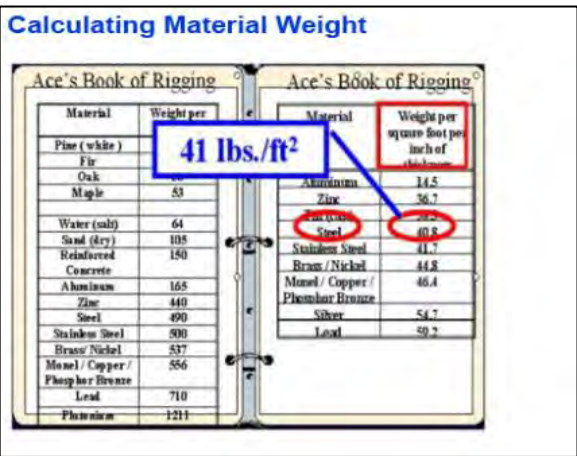

We find steel listed in the “Materials” column. The unit weight is 40.8 pounds per square foot, per inch thickness of steel plate. Now let's apply the rule we learned earlier in the lesson to make the math easier and give us a safety margin in our calculations. What was the rule on rounding that we should apply to this unit of weight? Round up! So, 40.8 pounds per square foot is rounded up to 41 pounds per square foot.

---



---



---



---

### Calculating Area and Materials Weight – Step 4

To calculate the weight of the plate, multiply the area 80 square feet by the unit weight of 41 pounds per square foot. The weight of the plate is 3,280 pounds. If 1-inch thick steel plate weighs 41 pounds per square foot, a 2-inch thick steel plate would weigh 82 pounds per square foot. What would 1/2 inch thick steel plate weigh per square foot? It would weigh 20.5 pounds.

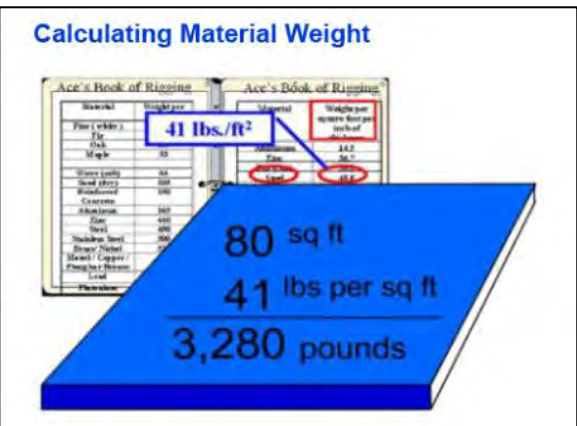

---



---



---



### Calculating Triangle Area

In this example, we have a triangular shape. How do we find the area of this plate?

Multiply the base times the height and divide by 2. 12 times 5, divided by 2. The area of this plate is 30 square feet.

---



---



---

#### Calculating Area - Triangle



Area of a triangle =  $\frac{\text{Base} \times \text{Height}}{2}$

$\frac{5' \times 12'}{2} = 30 \text{ sq. ft.}$

### Calculating Triangle Weight

To find the weight of this plate, we have to multiply the area (30 square feet) by the unit weight of the material per inch of thickness. The material is brass, and the thickness is 3 inches. To find the total weight of the material, we need to reference a table or chart to obtain the unit weight.

---



---



---

#### Calculating Weight - Triangle

Material	Weight per cubic foot	Material	Weight per square foot per inch thickness
Pine (white)	25	Aluminum	14.5
Fir	34	Zinc	36.7
Oak	50	Tin (cast)	38.3
Maple	53	Steel	49.8
Water (soft)	64	Stainless Steel	41.7
Sand (dry)	105	Brass / Nickel	44.8
Reinforced Concrete	150	Monel / Copper / Phosphor Bronze	40.4
Aluminum	165	Silver	54.7
Zinc	247	Lead	69.2
Steel	490		
Stainless Steel	505		
Brass / Nickel	537		
Monel / Copper / Phosphor Bronze	556		
Lead	710		
Phenolite	1211		

**44.8 lbs./ft<sup>2</sup>**  
**Rounded up 45 lbs.**

### Calculating Triangle Weight – Step 2

We now know that brass weighs 45 pounds per square foot, per inch of thickness. We multiply the thickness, 3 inches, by the unit weight of 45 pounds. The material weighs 135 pounds per square foot. Next, we multiply the area, 30 square feet, times the weight per square foot, 135 pounds. We find that this item weighs 4,050 pounds.

---



---



---

#### Calculating Weight - Triangle



Area = 30 sq. ft.  
 Thickness = 3"  
 Brass 45 lbs per inch of thickness

$3 \times 45 \text{ lbs./ft}^2 = 135 \text{ lbs. ft}^2$   
 $135 \text{ lbs./ft}^2 \times 30 \text{ ft}^2 = 4,050 \text{ lbs.}$

Weight of brass plate = 4,050 lbs.

### Calculating the Area of a Circle - Example

To calculate the area of a circle, multiply Pi, 3.14, by the radius squared. This steel plate is 4 feet in diameter. Therefore, the radius is 2 feet. The plate is 1 ½ inches thick.

To find the area, multiply Pi, or 3.14 times the radius squared. 3.14 times 2, times 2 equals 12.56 square feet.

To find the weight per square foot, multiply the plate thickness, 1 ½ inches, times the weight of 1 square foot of 1-inch thick steel. 1.5 times 41 equals 61.5 pounds.

To find the weight, multiply the area, 12.56 times the unit weight of 1 ½ inch thick steel plate which is 61.5 pounds. The weight of this circular steel plate is 772.44 pounds.

**Calculating Weight - Circle**

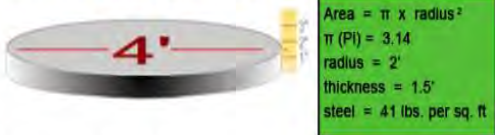

Step One: Area = 3.14 x 2<sup>2</sup>  
Area = 12.56 ft.

Step Two: Thickness x pounds per 1" thickness weight  
1.5 x 41 = 61.5 lbs. / ft<sup>2</sup>

Step Three: Area x lbs. per sq. ft. = weight of plate  
12.65 ft<sup>2</sup> x 61.5 lbs. = 772.44 lbs.

---



---



---



---

### Calculating the Area of a Circle - Rounding

Rounding numbers make calculations easier. Always round up. Rounding up gives a larger area and heavier weight, therefore an added safety margin. Round up the plate area and the weight. The area 12.56 square feet rounded is 13 square feet. The weight 61.5 pounds rounded is 62 pounds. 13 times 62 equals 806 pounds.

---



---



---

**Rounding Numbers**

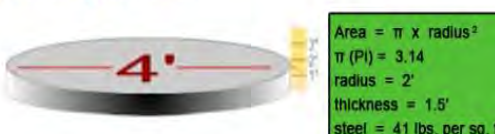

Step One: Area = 3.14 x 2<sup>2</sup>  
*Rounded Area* = 13 ft<sup>2</sup>

Step Two: Thickness x pounds per 1" thickness weight  
1.5 x 41 = *Rounded* 62 lbs. / ft<sup>2</sup>

Step Three: *Rounded Area* x *Rounded* lbs. per sq. ft. = weight of plate  
13 ft<sup>2</sup> x 62 lbs. = 806 lbs.

## Knowledge Check

- Select the best answer.** To find the weight of a piece of aluminum plate, you would multiply—
  - cubic feet times material weight per cubic foot
  - square feet times material weight per square foot based on a specific thickness
- Select the best answer.** A triangular shaped 1 inch thick metal plate has a base of 10 feet and a height of 15 feet. What is the area of the plate?
  - 75 square feet
  - 150 feet
  - 1,500 feet
  - 1,500 square feet
- Select the best answer.** A circular shaped  $\frac{1}{2}$  inch thick aluminum plate has a diameter of 7 feet. What is the area of the plate rounded up?
  - 7 square feet
  - 22 square feet
  - 22 feet
  - 39 square feet
- Select the best answer.** A complex shape of 1 inch thick aluminum plate has a rectangular area of 64 square feet and a triangular area of 16 square feet. If aluminum weighs 14 pounds per square foot, how much does the plate weigh (rounded up to the nearest hundred pounds)?
  - 1,000 pounds
  - 1,100 pounds
  - 1,200 pounds
  - 1,300 pounds
- Select the best answer.** A complex shape of 1 inch thick aluminum plate measures 6 feet long on the top edge, 8 feet edge on the left edge, 12 feet long on the bottom edge ending with a 10 foot long hypotenuse connecting back to the top edge. What is the correct equation to find the area of the triangular shape?
  - $8 \times 6 / 2$
  - $12 \times 10 / 2$
  - $8 \times 12 / 2$
  - $6 \times 12 / 2$
- Select the best answer.** The formula for determining the area of a triangular shaped object is—
  - Base x height / 2
  - Base x height x 2
  - Length x width x height
  - None of the above

### Calculating Volume

The volume of a square or rectangular object is figured as length times width multiplied by the height. The volume of a cylinder is Pi times the radius squared, times the height.

---



---



---

**Calculating Volume**

Volume = Length x Width x Height



Volume =  $\pi \times R^2 \times \text{Height}$   
 $\pi = 3.14$

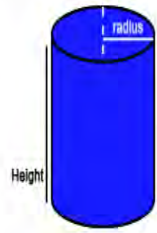

### Load Weight by Volume

To calculate weight by volume, we need to find the unit weight or weight per cubic foot for the material. We go back to the tables to find the weight for a cubic foot of fir wood. This time we will use the table on the left since the material weights listed here are based on the weight per cubic foot of material. Using the standard material weight chart, we find that fir weighs 34 pounds per cubic foot. If the weight were listed in fractions or decimals, such as 33.8 pounds per cubic foot, we would simplify the math by rounding 33.8 up to 34 pounds. Multiplying 80 cubic feet by 34 pounds equals 2,720 pounds. This stack of lumber weighs 2,720 pounds.

---



---



---

**Load Weight by Volume - Example Calculation**

Material	Weight per cubic foot
Pine (white)	25
Pine	34
Oak	35
Maple	35
Water (soft)	34
Sand (dry)	120
Reinforced Concrete	150
Aluminum	168
Zinc	442
Steel	490
Stainless Steel	500
Brass / Nickel	527
Mercury / Copper	584
Phosphor Bronze	588
Lead	710



80 cubic feet of fir lumber  
 X 34 pounds per cubic foot  
 -----  
 2,720 pounds load weight

### Volume of a Cylinder

What is the formula for finding the volume of a cylinder? To calculate the volume we must first find the area of the circular end. The formula for area is Pi times radius squared. Once we know the area, we simply multiply it times the height or length. So the formula we use to find the volume of a solid cylinder is, Pi times radius squared times the height. If the cylinder were lying down you would use its length in place of the height.

---



---



---

**Calculating the Area, Volume, and Weight of a Cylinder**

Area (ft<sup>2</sup>) of the circular end (area of a circle) =  $\pi \times \text{radius}^2$

Volume (ft<sup>3</sup>) of a solid cylinder =  $\pi \times \text{radius}^2 \times \text{height}$



Volume of a Cylinder  
 Volume of a Cylinder =  $\pi \times \text{Radius}^2 \times \text{Height}$

### Calculating the Volume of a Cylinder - Example

Let's calculate the volume of this cylinder. If the diameter of this object is 6 feet, what would the radius be? The radius would be 3 feet. The height is 10 feet. We multiply Pi, which is 3.14, times 3 feet times 3 feet. The result is 28.26 square feet.

Now, multiply 28.26 square feet, times the height 10 feet. The result is the volume of this cylinder, 282.6 cubic feet. If the cylinder is hollow, we will need to calculate the volume of the cylinder and the volume of the contents separately. Calculate the volume as if the cylinder is solid. Then calculate the volume of the hollow. Subtract the volume of the hollow section from the volume of the solid cylinder.

---



---



---

#### Calculating the Volume of a Cylinder

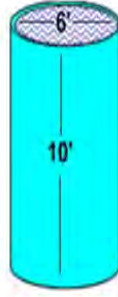

Dimensions:

- Height = 10'
- Diameter = 6'; Radius = 3'

Volume of a cylinder =  $\pi \times R^2 \times \text{Height}$   
 $= 3.14 \times (3' \times 3') = 28.26 \text{ sq. feet}$   
 $28.26 \text{ sq. feet} \times 10' = 282.6 \text{ cubic feet}$

Walls = 1" thick

### Calculating the Weight of a Cylinder

One inch steel plate weighs 40.8 pounds per square foot. The bottom plate is 6 feet in diameter, so the radius is 3 feet. 3 feet squared equals 9 square feet. We multiply 9 square feet by 3.14. This gives us the area, 28.26 square feet. We multiply this by the unit weight for steel plate of 40.8 pounds per square foot. The bottom plate weighs 1,154 pounds. Calculate the cylinder wall weight as a flat plate. Multiply Pi, (3.14) times the diameter, 6 feet, times the height, 10 feet. Multiply the area 188.4 square feet by the weight of steel plate, 40.8 pounds per square foot. The resulting weight is 7,687 pounds.

---



---



---

#### Calculating the Weight of a Cylinder

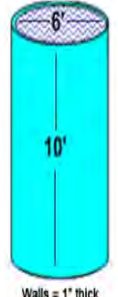

Bottom plate weight =  $\pi \times R^2 \times 40.8 \text{ lbs. ft}^2$

- Step 1  $3' \times 3' = 9 \text{ ft}^2$
- Step 2  $3.14 \times 9 \text{ ft}^2 = 28.26 \text{ ft}^2$
- Step 3  $28.26 \text{ ft}^2 \times 40.8 = 1,154 \text{ lbs.}$

Cylinder wall weight =  $\pi \times \text{diameter} \times \text{height} \text{ ft} \times \text{weight of materials}$

- Step 1  $3.14 \times 6' \times 10' = 188.4 \text{ ft}^2$
- Step 2  $188.4 \text{ ft}^2 \times 40.8 = 7,687 \text{ lbs.}$

Bottom Plate = 1,154 lbs.  
 Cylinder = 7,687 lbs.

Walls = 1" thick  
 Unit weight (steel 1")  
 40.8 lbs. ft<sup>2</sup>

### Calculating the Volume of a Cylinder

Using the volume calculation, let's find the weight of the water contained in this thin-walled cylindrical tank. Let's calculate the weight of this cylinder full of salt-water. We need to know the weight per cubic foot of salt water. Looking at our material weight chart we see saltwater weighs 64 pounds per cubic foot. We multiply the material weight times the cubic feet to find the weight of the water in the cylinder. 282.6 cubic feet times 64 pounds per cubic foot equals 18,086.4 pounds. Now, we will add up the weights. 1,154 pounds for the bottom plate, 7,687 pounds for the cylinder wall; and 18,087 pounds of water, for a total load of 26,928 pounds.

---

---

---

**Calculating the Weight of a Cylinder and its Contents**



Saltwater = 64 lbs ft<sup>3</sup>

Materials weight x cubic feet = weight of the water  
64 lbs/ft<sup>3</sup> x 282.6 ft<sup>3</sup> x = 18,086.4 lbs  
Rounded up = 18,087 lbs

Bottom Plate = 1,154 lbs  
Cylinder = 7,687 lbs  
Water = 18,087 lbs

---

Total Weight of cylinder and water = 26,928 lbs

Knowledge Check

- 7. **Select the best answer.** A box has 27 cubic feet of sand in it. Sand weighs 105 lbs. per cubic foot. The box weight 1,200 lbs. empty. The correct equation to find the total weight is—
  - A.  $27 \times 1,200 = 32,400 + 105 = 32,505$  lbs.
  - B.  $27 \times 105 = 2,835$  lbs.
  - C.  $27 \times 105 = 2,835 + 1,200 = 4,035$  lbs.
  
- 8. **Select the best answer.** A cylinder has a diameter of 12 feet and a height of 17 feet. What is the volume of the cylinder rounded up?
  - A. 204 cubic feet
  - B. 204 square feet
  - C. 7, 687 cubic feet
  - D. 1,922 cubic feet
  
- 9. **Select the best answer.** A cylinder is made of solid aluminum which has a unit weight of 165 pounds per cubic foot. What is the weight of this cylinder if the diameter is 4 feet and the height is 5 feet?
  - A. 10, 362 lbs.
  - B. 10,000 lbs.
  - C. 10,532 lbs.
  - D. 12,532 lbs.
  
- 10. **Select the best answer.** A rectangular shaped tank has a length of 24 feet, a width of 10 feet, and a height of 12 feet. What is the volume of the tank?
  - A. 2,400 square feet
  - B. 2,880 square feet
  - C. 2,880 cubic feet
  - D. 2,900 feet

Completion

---

---

---

<p><b>Completion</b></p> <p><b>Congratulations.</b></p> <p>You have completed the Determining Load Weight module.</p> <p>Click on the Exit button to return to the main module menu.</p>
--

## LOAD WEIGHT DISTRIBUTION

### Welcome

Welcome to the Load Weight Distribution module.

---

---

---

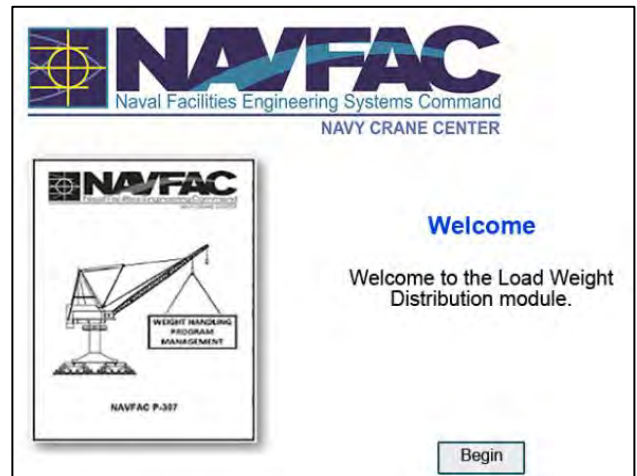

### Learning Objectives

Upon successful completion of this module, you will be able to explain the difference between the center of balance or balance point and the center of gravity, understand the importance of locating an object's center of gravity, calculate the center of gravity of various objects, discuss the determining factors of weight distribution to attachment points, apply the "Two legs carry the load" rule, explain the importance of weight distribution to attachment points, and calculate weight distribution to attachment points.

---

---

---

### Learning Objectives

Upon successful completion of this module, you will be able to:

- Explain the difference between Center of Balance (CB) and Center of Gravity (CG)
- Understand why Center of Gravity (CG) must be known
- Calculate the Center of Gravity (CG) of various objects
- Discuss what determines the amount of weight distributed to attachment points
- Apply the "Two legs carry the load" rule
- Explain the importance of weight distribution in attachment points
- Calculate weight distribution to attachment points

### Center of Balance

An object will rest in a state of balance when supported at its balance point. The balance point may not be located at the center of an object, but it is always directly below the center of gravity.

---

---

---

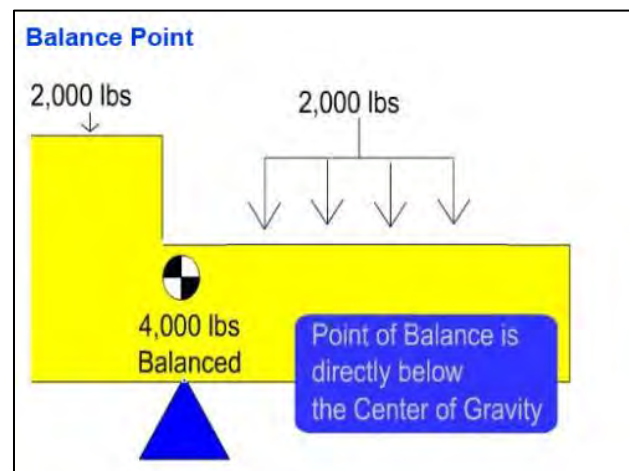



### Center of Gravity

The center of gravity is the point where the entire weight of the object would balance in any direction, as if all the weight were concentrated in that one point. It is a fixed point and does not change unless the shape of the object is altered. Center of gravity is generally located in the center of symmetrical objects made of like material. For non-symmetrical objects, it must be calculated and could be located outside the object. The hook must be centered over the CG before lifting.

---

---

---

**Center of Gravity (CG)**



- at the center of a solid symmetrical object
- is the fixed point where the weight of the object is centered
- must be calculated for non-symmetrical objects
- does not move unless the object is altered
- may be located outside of the object
- hook must be centered over the CG before lifting

### Why Find Center of Gravity

The location of the center of gravity will affect an object's reaction to movement. If the attachment points are below the center of gravity, the object will tip over more easily when moved. If the attachment points are above the center of gravity, the object is not likely to tip.

---

---

---

**Why Find the Center of Gravity (CG)?**

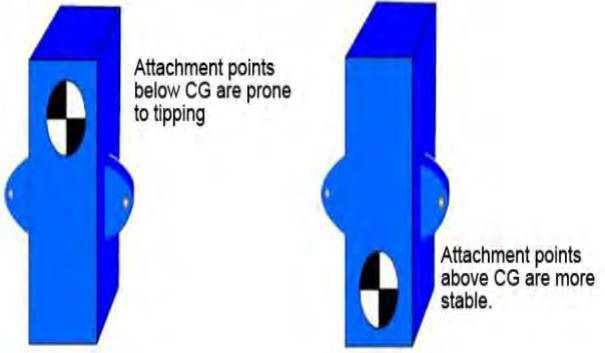

Attachment points below CG are prone to tipping

Attachment points above CG are more stable.

### Finding Center of Balance – Step One

The balance point of a symmetrical object will be directly under its center. To find the balance point of a complex shape, we must first break the object into symmetrical sections or components.

---

---

---

**Finding the Center of Balance - Step 1**

- Break the object into sections or components

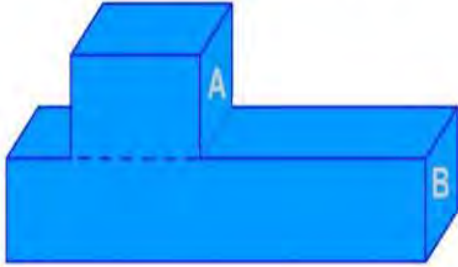

**Finding Center of Balance - Step 2**

The second step is to determine the weight of each section.

---



---



---

**Finding the Center of Balance - Step 2**

- Determine the weight of each section or component.
  - Aluminum weighs 165 pounds per cubic foot.

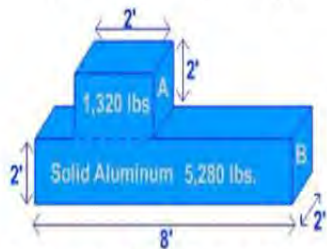

Part A =  $2' \times 2' \times 2' = 8 \text{ ft}^3 \times 165 \text{ lbs/ft}^3 = 1,320 \text{ lbs.}$   
 Part B =  $2' \times 8' \times 2' = 32 \text{ ft}^3 \times 165 \text{ lbs/ft}^3 = 5,280 \text{ lbs.}$   
 Add the selections:  $1,320 + 5,280 = 6,600 \text{ lbs.}$

**Finding Center of Balance - Step 3**

The next step is to measure from the reference end to the center of each section of the object.

---



---



---

**Finding the Center of Balance - Step 3**

- Measure from the reference end to the center of each section.

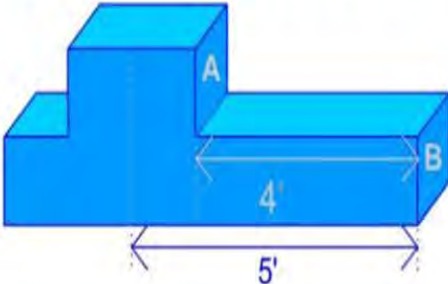

**Finding Center of Balance - Step 4**

Then, multiply the weight of each section, by the distance from the reference end to the center of that section. The result is called moment. Moment is an effect produced by a force at some distance from a fixed point, such as the center of gravity. Moment, like torque, is often described in foot-pounds or pound-feet.

---



---



---

**Finding the Center of Balance - Step 4**

- Multiply the weight of each section by the distance from the reference end to the center of each section.
  - Moment of Section A =  $1,320 \text{ lbs.} \times 5 \text{ ft.} = 6,600 \text{ ft lbs}$
  - Moment of Section B =  $5,280 \text{ lbs.} \times 4 \text{ ft.} = 21,120 \text{ ft lbs}$

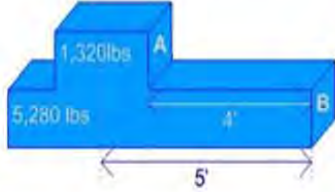

### Finding Center of Balance - Step 5

Add the moments together and divide this number by the total weight of the object. The balance point is where the moments, measured from each end, are equal.

---



---



---

### Pinpointing Center of Gravity – CG Height

In this example, the weight of section A is 2,640 pounds. The weight of section B is 5,280 pounds. Measure the distance from the reference end to the center of each section. Multiply the weight of each section by the distance from the reference end to the center of the section to obtain the moment. The distance from the reference line to the center of section A is 3 feet, and the distance from the reference line to the center of section B is one foot. The moment for section A is 7,920 pound-feet. The moment for section B is 5,280 pound-feet. Add the moments together and divide by the total weight to find the height of the center of gravity. 7,920 plus 5,280 equals 13,200 pound-feet. The weight is 2,640 plus 5,280 or 7,920 pounds. Now divide 13,200 by 7,920. The center of gravity is 1.666 feet up from the reference end. If we convert decimal feet to inches, this equals 1 foot, 8 inches.

### Pinpointing Center of Gravity – CG Depth

To find the depth of the center of gravity, follow the five-step process using the front of the object as the reference end for step 3. In this example, the end view shows the object is symmetrical. Therefore, we can assume the center of gravity is in the center of the object: one foot from the front.

---



---



---

### Finding the Center of Balance - Step 5

- Add the moments of each section (from step 4)
- Divide by the total weight (from step 2)
  - Moment: 6,600 ft. lbs. + 21,120 ft. lbs. = 27,720 ft. lbs.
  - Weight: 1,320 lbs. + 5,280 lbs. = 6,600 lbs.
  - 27,720 ft. lbs. / 6,600 lbs. = 4.2'

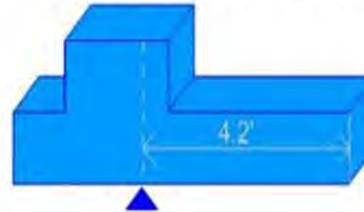

### Finding the Height of the Center of Gravity

**Multiply:**

- 3' x 2,640 lbs. = 7,920 lb. ft. of moment
- 1' x 5,280 lbs. = 5,280 lb. ft. of moment

**Add:**

- 7,920 + 5,280 = 13,200 lb. ft. of moment

**Divide:**

- 13,200 / 7,920 = 1.666'

CG is located 1.666 ft. above the Center of Balance

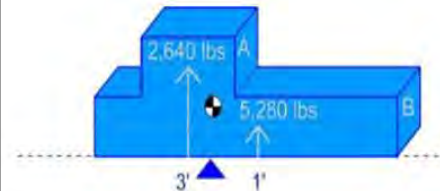

---



---



---

### Finding Depth of Center of Gravity (CG)

- If the end view of the object is symmetrical:
  - the CG can be assumed to be centered between the sides

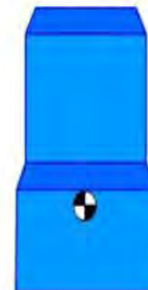

### Center of Gravity Pinpointed

The object's center of gravity is always directly above the balance point. It may be helpful to measure and temporarily mark the object's center of balance before rigging.

---



---



---

#### Center of Gravity (CG) Pinpointed

- The Center of Gravity is found directly above the balance point.
- When two sides are parallel, the CG is centered between the sides.
- When sides are not parallel, the CG must be calculated for each plane.

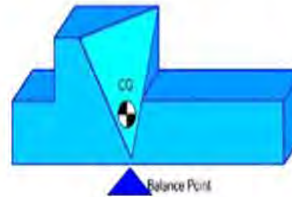

### Center of Gravity Review

Remember to estimate the location of the Center of Gravity in relation to the attachment points before rigging or lifting loads. If the center of gravity is difficult to estimate, you may need engineering assistance. Loads hoisted from the bottom without restraint are susceptible to tipping. Loads should be lifted from their top or restrained within the slings. If a load is hoisted without keeping the hook over the center of gravity, the load will shift as it clears the ground. Sometimes the rigging must be readjusted before making the lift.

---



---



---

#### Center of Gravity (CG) Review

- Estimate the location of the CG before choosing rigging.
- If the CG is difficult to determine, ask for engineering assistance.
- For safety, make sure the hook is over the CG before lifting.



### Weight Distribution

The center of gravity provides a quick reference for how the weight is distributed throughout a load. However, before planning the lift, it is necessary to refine how the load weight is distributed. Weight distribution determines what each attachment point will have to carry. This information ensures the selection of correctly rated rigging gear.

---



---



---

#### Weight Distribution

- determines the load at each attachment point

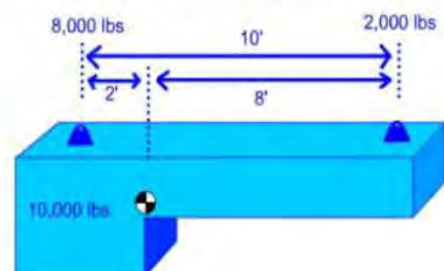

### Wrong Assumption

A common assumption is that 4 legs divide the load weight into 4 equal parts. Each leg then carries 25% of the load. Most often, this is not true.

---

---

---

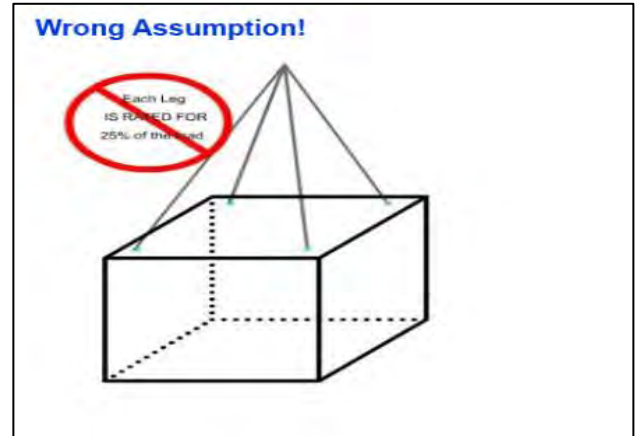

### How many legs really carry the load?

We now understand that each leg will not always carry its share of the load. In this example, one sling is longer than the others. Therefore, that attachment point will not carry its share of the load. No two slings are fabricated exactly the same length. When one sling is longer than the others, when shackles or other hardware are different brands or sizes, or when one attachment point is higher than the others, one or more attachments may not carry any load at all. Don't assume that all legs will carry their share of the load.

---

---

---

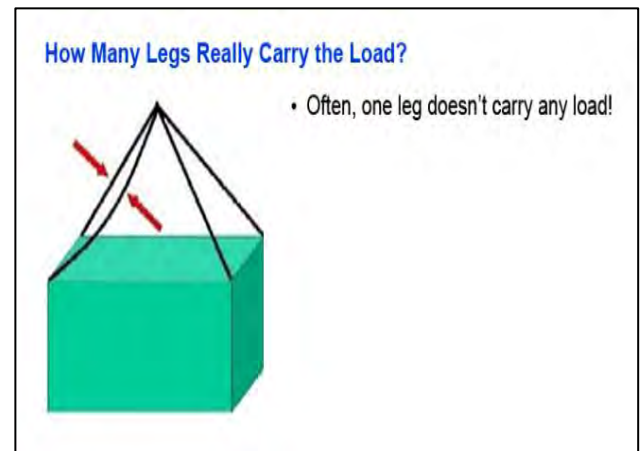

### A Safe Assumption

Here is a safe assumption: At any given time, any two legs may carry the load, even if three or more legs are used. The two-legs-carry-the-load rule helps us to compensate for different sling lengths, attachment points at different elevations, and load flex. Gear selections should be based on two legs being able to carry the load. For example, if an object weighs 10,000 pounds, then each leg would require a rated load of at least 5,000 pounds.

---

---

---

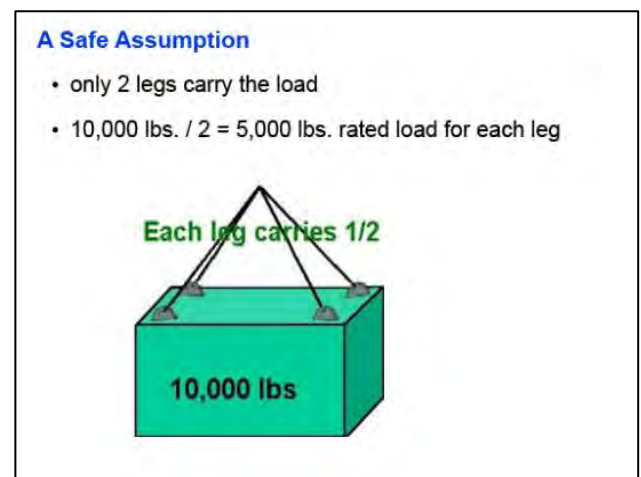

### Determining Leg Weight

Gear selection is dependent upon how much weight is carried by each leg - the load's weight distribution. The distances between the center of gravity and the attachment points will determine how much of the weight each attachment point will carry.

---

---

---

**Determining Leg Weight**  
How much weight does each leg carry?

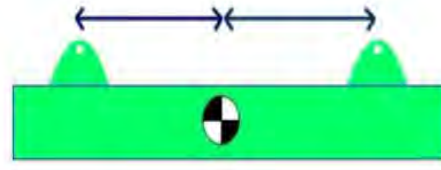

The diagram shows a green rectangular load resting on two green legs. A black and white circular marker represents the center of gravity, positioned in the middle of the load. Two blue double-headed arrows above the load indicate the distance from the center of gravity to each leg.

### Equal Leg Weight

This drawing represents a load. Notice the difference in weight distribution as the center of gravity changes distance from each attachment point. In this first example, each attachment carries equal weight because the center of gravity is equal distance between the attachment points. Watch the left attachment point as we move the center of gravity.

---

---

---

**Equal Weight Distribution**

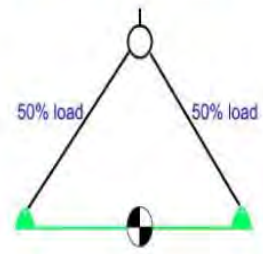

The diagram shows a triangular load with a white circle at the top vertex. Two green legs are at the bottom vertices. A black and white circular marker representing the center of gravity is positioned exactly in the middle between the two legs. Labels '50% load' are placed next to each leg.

- When distances between the CG and attachment points are equal, weight distribution is also equal.

### Unequal Leg Weight

In the second example, the weight is greatest in the left attachment point because it's closest to the center of gravity. When one attachment point is closer to the center of gravity than the other attachment point, it carries more weight. It carries 75% of the weight, and the opposite end carries 25%.

---

---

---

**Unequal Weight Distribution**

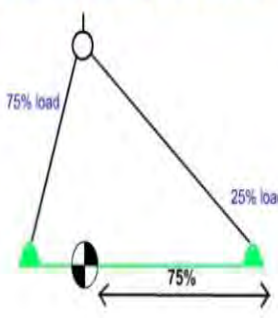

The diagram shows a triangular load with a white circle at the top vertex. Two green legs are at the bottom vertices. A black and white circular marker representing the center of gravity is positioned closer to the left leg. A blue double-headed arrow below the load indicates the distance from the center of gravity to the right leg, labeled '75%'. Labels '75% load' and '25% load' are placed next to the left and right legs respectively.

- When distances between the CG and attachment points are unequal, weight distribution is inversely proportionate.

### Calculating Weight Distribution

Now, let's move beyond estimating and show how to calculate the weight distribution. To calculate weight distribution, you must know the object weight, the location of the center of gravity, and the distance of each attachment point from the center of gravity.

---



---



---

### Weight Distribution Example

If we want to find out how much weight is distributed to the attachment closest to the center of gravity, we divide the 8-foot distance by the overall distance between attachment points, which is 10 feet. Then, we multiply this answer by the total weight of the object. Eight divided by 10, times 10,000 equals 8,000 pounds.

---



---



---

**Information Needed to Calculate Weight Distribution**

Must know:

- object weight
- location of CG
- distance of each attachment point from CG

**Weight Distribution Example**

$(2' \div 10') \times 10,000 \text{ lbs.} = 2,000 \text{ lbs.}$

$(8' \div 10') \times 10,000 \text{ lbs.} = 8,000 \text{ lbs.}$

### Knowledge Check

- 1. Select the best answer.** An attachment point is 2 feet from the center of gravity, and the other attachment point is 6 feet from the center of gravity. What is the correct percentage of weight distribution to each attachment point with the attachment point 2 feet from the center of gravity being listed first?
  - A. 25%, 75%
  - B. 33%, 66%
  - C. 50%, 50%
  - D. 75%, 25%
- 2. Select the best answer.** Center of gravity is best described as—
  - A. always being in the center of an object
  - B. where all the weight is concentrated
  - C. where the item balances
- 3. Select the best answer. True or False:** The center of gravity is located below the center of balance.
  - A. True
  - B. False
- 4. Select the best answer. True or False:** The center of gravity is always located within the object.
  - A. True
  - B. False
- 5. Select the best answer.** Attachment point #1 is 6 feet from the center of gravity, and attachment point #2 is 3 feet from the center of gravity. There is a 10,000 lb. load attached. What is the correct equation to find the weight distribution for attachment point #1?
  - A. 9 divided by 3 multiplied by 10,000 ( $9 / 3 \times 10,000$ )
  - B. 3 divided by 9 multiplied by 10,000 ( $3 / 9 \times 10,000$ )
  - C. 3 divided by 6 multiplied by 10,000 ( $3 / 6 \times 10,000$ )
  - D. 6 divided by 3 multiplied by 10,000 ( $6 / 3 \times 10,000$ )
- 6. Select the best answer. True or False:** The center of gravity will always find its way directly under the crane hook when lifted off the ground.
  - A. True
  - B. False

### Completion

---

---

#### Completion

Congratulations.

You have completed the Load Weight Distribution module.

Click on the Exit button to return to the main module menu.



## SLING ANGLE STRESS

### Welcome

Welcome to Sling Angle Stress.

---

---

---

### Learning Objectives

Upon successful completion of this module, you will be able to define sling angle stress and explain why it must be accounted for, calculate sling angle stress, and determine the minimum sling length and rated capacity for lifts.

---

---

---

### What is Sling Angle Stress?

What is sling angle stress? It is the added force created in the rigging when the slings are not perfectly plumb, vertical, and parallel.

---

---

---



**Welcome**  
Welcome to Sling Angle Stress.

Begin

### Learning Objectives

Upon successful completion of this module, you will be able to:

- Define sling angle stress and explain why it must be accounted for
- Calculate sling angle stress
- Determine the minimum sling length and rated capacity for lifts

### What is Sling Angle Stress?

- the added force induced when the sling angle is not perpendicular to the center of gravity.

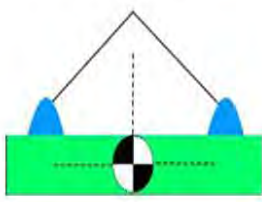

### Sling Angle Stress Illustration

It may be beneficial to use an illustration that we can relate to. Though this is not exactly sling angle stress, it illustrates the concept very well.

---

---

---



### Sling Angle Stress 90 Degrees

Here's Ace. He is holding a fifty-pound weight in each hand. His arms are vertical, similar to a 90° horizontal sling angle. The amount of stress in Ace's arms is equal to the amount of weight he's holding, fifty pounds. See what happened as Ace moved his arms increasingly further away from his body.

---

---

---



### Sling Angle Stress 45 Degrees

When Ace has his arms at a 45° angle, the stress in his arms increases even more. The stress increase is 42% of the weight he's holding. It feels like he's holding 71 pounds in each arm.

---

---

---

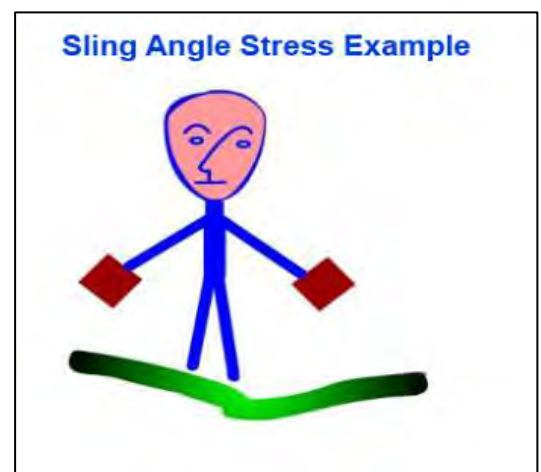

### Sling Angle Stress 30 Degrees

At a 30° angle, the amount of stress in Ace's arms increases further. The stress increase at 30° is 100% of the weight he's holding. Now Ace feels like he's holding 100 pounds in each arm even though the weight is still actually 50 pounds. This same effect, called sling angle stress, occurs in rigging gear because the legs of a lift are almost always at angles. This additional stress must be considered when selecting rigging gear.

---

---

---



### Choosing Your Gear

The two-leg rule is followed when choosing gear capacities for a lift. Rigging gear must have a capacity greater than the applied load. The load applied to the rigging gear includes the weight carried by the attachment points multiplied by the sling angle factor.

---

---

---



### What does it affect?

Nearly every lift creates a triangle. All of the components that make up the sides of a lift triangle are affected by sling angle stress including the attachment points on the load, the crane hook, the rigging gear, and the load itself. Sling angle stress can cause the load to flex and sag. Excessive sling angle stress can cause a choker hitch or basket hitch to crush a fragile item.

Remember, sling angle stress does not change the weight of the load being lifted, only the load on the rigging.

---

---

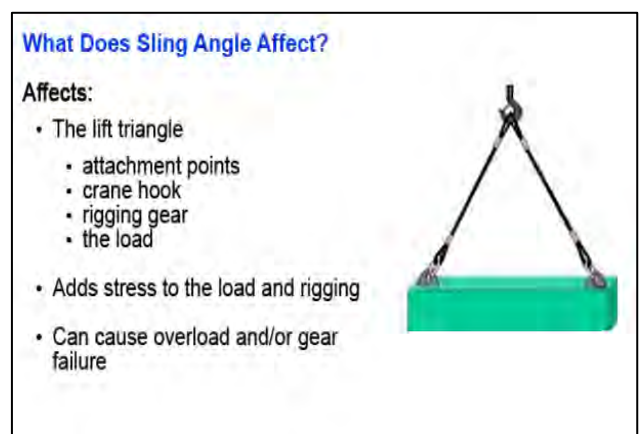

### Minimizing Sling Angle Stress

Sling angle stress can be minimized by using spreaders or other below the hook lifting devices. Lifting beams or strong-backs can help ensure each sling is carrying its share of the load and that the load remains level. Sling angles may still affect the rigging gear between the hook and spreaders, even if the slings between the spreader and the load are vertical.

---

---

---

### Minimizing Sling Angle Stress

- Spreader bars allow legs to be rigged perpendicular to the center of gravity.
- Remember to account for sling angle between the hook and spreader.



### Sling Angle Stress Summarized

When referring to the effects of sling angle, we refer to horizontal sling angle. In other words, we are measuring the angle created between the sling and a horizontal line through the attachment points. Sling angle stress is proportional to the degree of the angle from horizontal. The more vertical the angle - the less added force. The more horizontal the angle - the greater the added force. Let's look at this principle on a load.

---

---

---

### Sling Angle Stress Summarized

Stress is proportional to the degree of the angle:

- the larger the angle, the less added force
- the smaller the angle, the more added force

### Effects of Sling Angle Stress: 60° Angle

At a 60° angle, the load on the rigging has increased to 1,155 pounds. Keep in mind, each leg has 1,155 pounds of stress even though only one leg is shown. 60° is the preferred angle.

---

---

---

### Effects of Sling Angle Stress - 60 Degree Angle

- At a 60° angle:
  - Sling stress = 1,155 lbs. per sling

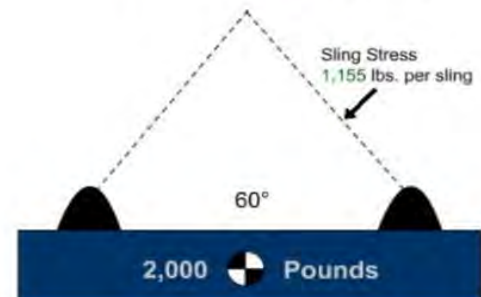

### Effects of Sling Angle Stress: 45° Angle

At a 45° angle, the load has increased to 1,414 pounds in each sling. That's nearly a 42% increase.

---

---

---

**Effects of Sling Angle Stress - 45 Degree Angle**

- At a **45°** angle:
  - Sling stress = **1,414** lbs. per sling



The diagram illustrates a 2,000-pound load on a blue base. Two slings are attached to the load at a 45-degree angle. A dashed line indicates the angle between the slings. An arrow points to the slings with the text 'Sling Stress 1,414 lbs. per sling'. A scale icon shows '2,000 Pounds'.

### Effects of Sling Angle Stress: 30° Angle

At a 30° angle, the stress has increased to 2,000 pounds. Each sling now has a load equal to the weight of the object. That is a 100% increase.

Never lift with less than a 30° angle without engineering approval.

---

---

---

**Effects of Sling Angle Stress - 30 Degree Angle**

- At a **30°** angle:
  - Sling stress = **2,000** lbs. per sling
  - **Never lift at less than a 30° sling angle without engineering approval**



The diagram illustrates a 2,000-pound load on a blue base. Two slings are attached to the load at a 30-degree angle. A dashed line indicates the angle between the slings. An arrow points to the slings with the text 'Sling Stress 2,000 lbs. per sling'. A scale icon shows '2,000 Pounds'.

### Effects of Sling Angle Stress: 15° Angle

At a 15° angle, the load has increased to 3,860 pounds. That's a 286% increase in each sling.

---

---

---

**Effects of Sling Angle Stress - 15 Degree Angle**

- At a **15°** angle:
  - Sling stress = **3,860** lbs. per sling
  - **Never lift at less than a 30° sling angle without engineering approval**



The diagram illustrates a 2,000-pound load on a blue base. Two slings are attached to the load at a 15-degree angle. A dashed line indicates the angle between the slings. An arrow points to the slings with the text 'Sling Stress 3,860 lbs per sling'. A scale icon shows '2,000 Pounds'.

### Effects of Sling Angle Stress Summary

At a 60° angle, the load on the rigging has increased to 1,155 pounds. Keep in mind, each leg has 1,155 pounds of stress even though only one leg is shown. 60° is the preferred angle. At a 45° angle, the load has increased to 1,414 pounds in each sling. That's nearly a 42% increase. At a 30° angle, the stress has increased to 2,000 pounds. Each sling now has a load equal to the weight of the object. That is a 100% increase. Never lift with less than a 30° angle without engineering approval. At a 15° angle, the load has increased to 3,860 pounds. That's a 286% increase in each sling.

---

---

---

### Why Must We Account for It?

Not accounting for sling angle stress can lead to overloaded rigging gear and even catastrophic failure.

---

---

---

### Selecting Minimum Rated Capacity

Remember, two legs must have the capacity to lift the weight of the object plus the added force from sling angle stress. After we calculate the sling angle stress, we can determine the minimum requirements for our rigging gear.

---

---

---

**Effects of Sling Angle Stress Summary**

**60° angle** - the load increases to 1,155 lbs. Each leg has 1,155 lbs. of stress - a **16% increase**. A 60° sling angle is the preferred angle to use.

**45° angle** - the load increases to 1,414 lbs. Each leg has 1,414 lbs. of stress - a **42% increase**.

**30° angle** - the load increases to 2,000 lbs. Each leg has 2,000 lbs. of stress - a **100% increase**.

**15° angle** - the load increases to 3,860 lbs. Each leg has 3,860 lbs. of stress - a **286% increase**.



**Why Account for Sling Angle Stress?**

Sling angle stress can cause overload and/or gear failure!

**Selecting Minimum Rated Capacity**

Two legs must have the minimum rated capacity to lift the object and the added force caused by sling angle stress.

### Determining Minimum Rated Capacity

There are several ways to determine sling angle stress. We will use the angle factor chart, as it is readily available and easy to use.

---



---



---

#### Determining Sling Angle Stress

- There are many ways to determine sling angle stress
- We will use an Angle Factor Chart
  - readily available
  - easy to use

### Using an Angle Factor Chart

To use an angle factor chart, you first need to determine the sling angle. Sling angle can be determined mathematically or measured. Once you have determined the sling angle, find the corresponding angle factor, and multiply that number by the weight carried in each leg. When you look at the angle factor column, you will notice a dramatic increase for angles less than 30°. That's why we do not use sling angles less than 30° unless authorized by an engineering document.

---



---



---

#### Using an Angle Factor Chart

Horizontal Angle	Angle Factor
90	1.000
85	1.004
80	1.015
75	1.035
70	1.064
65	1.104
60	1.155
55	1.221
50	1.305
45	1.414
40	1.555
35	1.742
30	2.000
25	2.364
20	2.924
15	3.861
10	5.747
5	11.490

- To use an angle factor chart:
- determine sling angle
  - locate the angle on the chart
  - use the corresponding angle factor
  - multiply angle factor by the weight carried in the leg

### Angle Factor Chart Example

This shape represents the lift we are about to make. Let's say that the angle created by the slings we use is 45°. The angle factor for a 45° angle is 1.414. We must multiply the angle factor, 1.414, by the weight carried in the leg. How much weight will the leg carry? That's right, 5,000 pounds. 1.414 times 5,000 equals 7,070 pounds. This is the total stress in each leg. This number represents the minimum gear capacity that can be used for the lift.

---



---



---

#### Angle Factor Chart Example

Horizontal Angle	Angle Factor
90	1.000
85	1.004
80	1.015
75	1.035
70	1.064
65	1.104
60	1.155
55	1.221
50	1.305
45	1.414
40	1.555
35	1.742
30	2.000
25	2.364
20	2.924
15	3.861
10	5.747
5	11.490

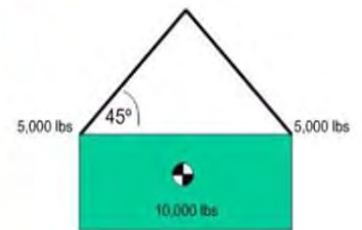

$1.414 \times 5,000 \text{ lbs.} = 7,070 \text{ lbs. in each leg.}$

### What is Angle Factor?

Remember the lift triangle? Now the whole triangle idea really comes into play. The sling angle factor is a ratio of the side of the lift triangle, which in this case is the sling and the height of the triangle. To find it, divide the sling length by the height of the lift triangle. The height is the distance between the bearing area of the hook and an imaginary line running horizontally from the bearing area of the attachment point. If you cannot measure the height, it can be found mathematically.

---



---



---

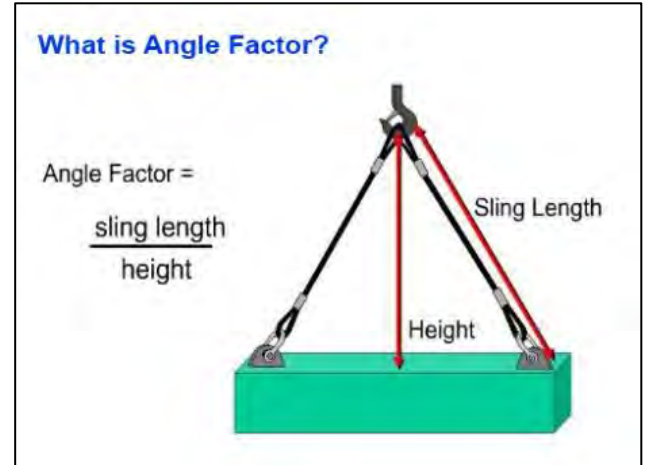

### How to find Height

The Pythagorean Theorem states that the length of a side of a right triangle squared equals the length of the base squared plus the height squared. A squared plus B squared equals C squared. Here the height of the lift triangle is A, the horizontal base is B, and length of the sling is C. Only A, the height, is unknown. To find the unknown height A, use this variation: C squared minus B squared equals A squared.

---



---



---

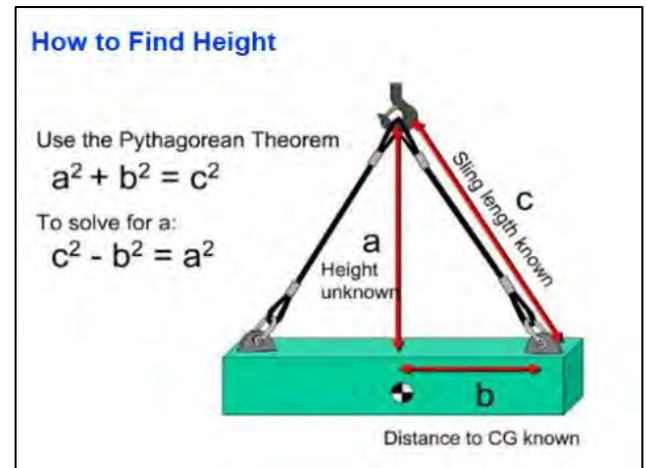

### Finding Height

Use C squared minus B squared equals A squared to solve for height. The sling C is twenty feet long. Multiplying the sling length times itself gives us C squared. In this case, that is twenty times twenty or four hundred. We measure the horizontal distance from the bearing area of the attachment to the top of the load directly above center of gravity. This dimension B is ten feet. We multiply this number by itself. Ten times 10 equals 100. Subtract 100, which is B squared, from 400, which is C squared. Therefore, A squared equals 300. Now we use the square root function on our

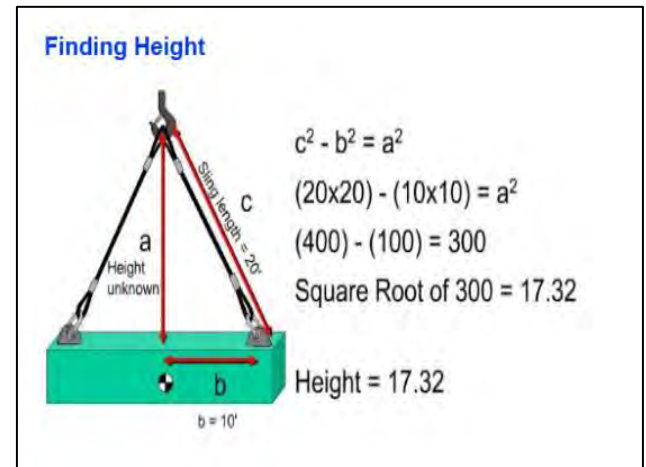



calculator to calculate the square root of 300. The height equals the square root of 300, which is 17.32 feet.

---



---



---

**Finding Angle Factor**

Remember, the angle factor equals sling length divided by height. We just found the height of the lift triangle. Now, here's how to find the angle factor: The sling is 20 feet long, and we found the height to be 17.32 feet. 20 divided by 17.32 equals 1.155. This is our angle factor. Finally, we will multiply the angle factor by the amount of weight at the attachment point.

---



---



---

**Finding Angle Factor**

Sling Length ÷ Height  
 20' / 17.32' = Angle Factor 1.155

Horizontal Angle	Angle Factor
90	1.000
89	1.004
88	1.015
87	1.035
86	1.064
85	1.104
84	1.155
83	1.221
82	1.305
81	1.414
80	1.555
75	1.742
70	2.000
65	2.364
60	2.774
55	3.251
50	3.913
45	4.755
40	5.773
35	7.000
30	8.660
25	10.974
20	14.142
15	18.011
10	22.981
5	29.540

**Solving Sling Angle Stress Mathematically**

Now, we can use everything we've covered thus far to solve for sling angle stress. Here's the formula: Sling length divided by height, times the weight distributed to each leg. Remember, weight distribution is determined by the distance from the center of gravity to the attachment points. This works for all lifts with level attachment points.

---



---



---

**Solving for Sling Angle Stress Mathematically**

(Sling Length ÷ Height) x Weight Distribution = Sling Angle Stress

### 60 Degree Sling Angle

60° is the preferred sling angle. At 60°, the load in the slings increases by 16%.

---

---

---

**60 Degree Sling Angle**

Preferred sling angle:

- Only a 16% load increase
- Easy to select slings

But...

- best sling lengths are not always available
- rigging configuration may restrict length
- overhead clearance may be restricted

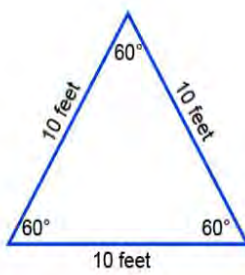

The diagram shows an equilateral triangle with all three sides labeled '10 feet' and all three interior angles labeled '60°'.

### Selecting Appropriate Sling Lengths for a 60 Degree Sling Angle

To ensure your slings will have at least a 60° sling angle, simply measure the distance between attachment points. Measure diagonally when there are more than two attachment points because it's the longest distance. Then select a sling that is as long or longer than the distance measured. If you use this method to select your slings, you will never have a sling angle less than 60°.

---

---

---

**Selecting Appropriate Sling Length for a 60 Degree Sling Angle**

- measure the distance between attachment points (20')
- select a sling as long as the distance or longer
  - in this case, 20 feet

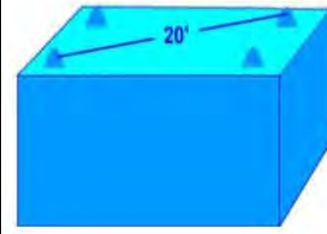

The diagram shows a blue 3D rectangular object. A diagonal line is drawn across the top surface, with arrows at both ends pointing to attachment points. The diagonal is labeled '20'.

### Selecting Minimum Rated Capacities for a 60 Degree Sling Angle

Now, we can easily determine the stress in the rigging before we and attach the gear. Let's say the weight of the object is 5,000 pounds. How much weight would each attachment point carry? Each would carry 2,500 pounds. What is the angle factor for a 60° sling angle? The angle factor is 1.155. Multiply the angle factor, 1.155, times the weight distributed to the attachment point, 2,500 pounds. 2,888 pounds is the stress in the rigging gear and attachment points. It is also the minimum capacity for all rigging for this lift.

---

---

---

**Selecting Minimum Rated Capacity for a 60 Degree Sling Angle**



The diagram shows a green 3D rectangular object. A weight of '5,000 lbs.' is indicated on the front face. Three attachment points are shown on the top surface, each with a label '2,500 lbs.' pointing to it.

60° angle factor of 1.155

$1.155 \times 2,500 \text{ lbs.} = 2,888 \text{ lbs. stress}$

Minimum capacity sling and rigging gear require 2,888 lbs.

### Selecting Minimum Rated Capacities for a 30 Degree Sling Angle

Using the same weight, let's look at the minimum rated capacities for a 30° sling angle. The angle factor for 30° is 2. At a 30° sling angle, the rigging and attachment point stress will double. Two times 2,500 pounds equals 5,000 pounds of stress. The minimum capacity sling and rigging gear required is five thousand pounds.

---

---

---

### Not Level nor Equal Distance from CG

Where the center of balance is not equally distant between attachment points or when attachment points are on different levels, sling angle stress will not be equal between legs and extra calculations will be required. Contact your supervisor and consult the activity engineers for guidance when there is a question about sling angle stress for these types of lifts.

---

---

---

#### Minimum Rated Capacity at 30 Degrees



30° angle factor of 2.00

$$2.00 \times 2,500 \text{ lbs.} = 5,000 \text{ lbs. stress}$$

Minimum capacity sling and rigging gear require 5,000 lbs.

#### Unequal Distances from the Center of Gravity

- Never assume sling angle stress is equal between legs
- Calculations are required to find sling angle stress

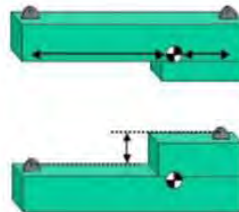

### Knowledge Check

- 1. Select the best answer. True or False:** A 60° sling angle will be formed when you match the sling length to the diagonal distance between attachment points.
  - A. True
  - B. False
  
- 2. Select the best answer.** An object has a length of 5 feet, a width of 3 feet, and a distance of 5 feet 6 inches between attachment points. What length slings would you select to ensure the horizontal sling angle was 60° or greater?
  - A. 3 feet
  - B. 4 feet
  - C. 5 feet
  - D. 6 feet
  
- 3. Select the best answer.** To find the sling angle stress—
  - A. multiple the weight in the attachment point with the height of the lift triangle
  - B. multiple the weight of the item with the distance between attachment points
  - C. multiple the weight of the item with the rated capacity of the gear
  - D. multiply the weight in the attachment point with the angle factor

### Completion

---

---

---

#### Completion

**Congratulations.**

**You have completed the Sling Angle Stress module.**

Click on the Exit button to return to the main module menu.

## **COMPLEX AND NON-COMPLEX LIFTS**

### Welcome

Welcome to the Complex and Non-Complex Lifts module.

---

---

---

### Learning Objectives

Upon successful completion of this module, you will be able to define complex and non-complex lifts, identify complex lifts, and state complex lift requirements.

---

---

---



### Non-Complex Lifts

Non-complex lifts are ordinary in nature, do not require direct supervisory oversight, and are made at the discretion of the rigger in charge.

---

---

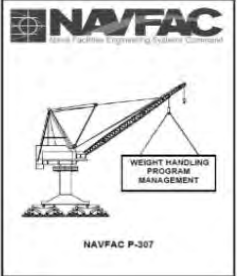
---



**Welcome**

Welcome to the Complex and Non-complex Lifts module.

Begin

### Learning Objectives

Upon successful completion of this module, you will be able to:

- Define the two types of lifts:
  - Complex
  - Non-Complex
- Identify complex lifts
- State the complex lift requirements

### Non-Complex Lifts



Non-complex lifts are:

- ordinary in nature
- not required to have oversight
- directed by the rigger-in-charge

## Complex Lifts Overview

Complex lifts have a moderate to high level of risk. Activities are required to identify complex lifts and prepare detailed written procedures for their execution. Procedures may be in the form of standard instructions or detailed procedures specific to a lift.

---

---

---

### Complex Lifts Overview

#### Complex lifts:

- have a moderate to high risk level
- require a written procedure (including rigging sketches where required)
- may be standard instructions or detailed procedures

## Complex Lift Categories

Complex lifts include hazardous materials, large and complex geometric shapes, lifts of personnel, lifts exceeding 80 percent of the certified capacity of the crane's hoist and lifts exceeding 50 percent of the hoist capacity for a mobile crane mounted on a barge (excluded from this rule are lifts with jib cranes, pillar jib cranes, fixed overhead hoists and monorails, and lifts of test weights during maintenance or testing when directed by a qualified load test director), lifts of submerged or partially submerged objects, multiple crane or multiple hook lifts on the same crane, lifts of unusually expensive or one-of-a-kind equipment or components, lifts of constrained or potentially constrained loads (a binding condition), and other lifts involving non-routine operations, difficult operations, sensitive equipment, or unusual safety risks.

### Complex Lift Categories

- Hazardous materials
  - Large and complex geometric shapes
  - Personnel lifts
  - Lifts exceeding 80% of the certified capacity of the crane's hoist used for the lift (exceeding 50% hoist capacity for barge-mounted mobile cranes)
    - lifts with jib cranes, pillar jib cranes, fixed overhead hoists, and monorails are excluded
  - Lifts of submerged or partially submerged objects
  - Multiple crane or multiple hook lifts
  - Lifts of unusually expensive or one-of-a-kind equipment or components
  - Lifts of constrained or potentially constrained loads (binding condition)
  - Other lifts including non-routine operations, difficult operations, sensitive equipment, or unusual safety risks
- 
- 
- 

## Procedures

Activities shall identify complex lifts and prepare procedures (including rigging sketches where required) for conducting these lifts. Procedures may be standard written instructions or detailed procedures specific to a lift.

A supervisor or working leader must review onsite conditions and conduct a pre-job briefing for all complex lifts. A rigger supervisor, operator supervisor, or a rigging or crane operator working leader shall review onsite conditions for complex lifts and shall perform a pre-job briefing before each complex lift. Any newly

### Complex Lift Procedures

#### Activities shall:

- identify complex lifts
- prepare procedures (including rigging sketches where required) for conducting these lifts

#### A rigger supervisor, operator supervisor, or working leader shall:

- review on-site conditions
- perform a pre-job briefing
- supervise:
  - lifts over 80% of the certified capacity
    - except for category 3 cranes
  - multiple hook lifts when the weight exceeds 80% of the certified capacity of any hoist
  - lifts of ordnance involving the use of tilt fixtures

assigned personnel shall be briefed by the supervisor or working leader.

A rigger supervisor, operator supervisor, or working leader shall personally supervise lifts exceeding 80 percent of the certified capacity of the crane's hoist used for the lift (except for lifts of ordnance with category 3 cranes and all lifts with jib cranes, pillar jib cranes, fixed overhead hoists, and monorails), multiple-hook lifts when the weight of the object being lifted exceeds 80 percent of the certified capacity of any hoist used for the lift, and lifts of ordnance involving the use of tilt fixtures. Subsequent identical lifts by the same crew may be done under the guidance of the rigger-in-charge.

---

---

---

---

---

---

---

---

### Complex Lift Exceptions

Exceptions to the complex lift requirements include lifts over 80% of the certified capacity made with jib cranes, pillar jib cranes, fixed overhead hoists, and monorail cranes. These cranes are usually smaller capacity cranes used primarily to service only one workstation, machine or area.

Lifts of test weights during maintenance or load test are excluded from the complex lift requirements. Ordnance lifts covered by NAVSEA OP 5 in lieu of the NAVFAC P-307 are also excluded, except for lifts using tilt fixtures, lifts where binding may occur, lifts of submerged loads, multiple crane or multiple hook lifts.

#### Lifts Not Considered Complex Lifts

- Lifts over 80% of the certified capacity made with jib cranes, pillar jib cranes, fixed overhead hoists, and monorail cranes
- Lifts of test weights during load test
- Lifts with cranes designed for lifting with coupled hooks
- Lifts of ordnance in accordance with NAVSEA OP-5; except for lifts using tilt fixtures, lifts where binding may occur, lifts of submerged loads, multiple crane or multiple hook lifts

---

---

---

### Knowledge Check

1. **Select the best answer.** Detailed written procedures are required for—
  - A. all lifts
  - B. complex lifts
  - C. non-complex lifts
  - D. some lifts
  
2. **Select the best answer.** For all complex lifts, a rigger supervisor, operator supervisor, or a rigging or crane operator working leader shall review onsite conditions and shall—
  - A. conduct a pre-job briefing
  - B. define the crane operating envelope
  - C. inspect all rigging gear
  - D. select the rigging gear
  
3. **Select the best answer.** Lifts of test weights during maintenance or load tests are—
  - A. evaluated according to the complex lift requirements
  - B. excluded from the complex lift requirements
  - C. included in the complex lift requirements
  - D. routine lifts because they are not complex shapes
  
4. **Select the best answer.** A crane with a capacity of 100,000 pounds is performing a lift of 40,000 pounds. This is a(n)—
  - A. complex lifts
  - B. hazardous lift
  - C. non-complex lift
  - D. overload lift

### Hazardous Materials

Lifts of hazardous materials, for example poisons, corrosives, and highly volatile substances are complex lifts.

Materials such as oxygen, acetylene, propane or gasoline in bottles, cans or tanks that are properly secured in racks designed for lifting by a crane are excluded.

---

---

---

#### Hazardous Materials

**Includes lifts of:**

- poisons
- corrosives
- highly volatile substances

**Excluded materials:**

- oxygen
- acetylene
- propane or gasoline

must be in bottles, cans, or tanks that are properly secured in racks designed for lifting by a crane





### Lift Requirements for Complex Geometric Shapes

Complex lifts also include large and complex shapes. For example, objects with large sail area that may be affected by winds, objects with attachment points at different levels requiring different length slings, and odd shaped objects where the center of gravity is difficult to determine.

---

---

---

#### Large Complex Geometrical Shapes

- Complex lifts also include complex shapes.
- Objects with:
  - large surface area
  - multi-level attachment points
  - difficult center of gravity



### Lift Requirements for Personnel Lifts

Use cranes for lifting personnel only when no safer method is available. Cranes, rigging gear, and personnel platforms shall conform to OSHA requirements 29 CFR Part 1926.1431 and ASME B30.23. The total weight of the loaded personnel platform and rigging shall not exceed 50% of the rated capacity of the hoist.

A trial lift with at least the anticipated weight of all personnel and equipment to be lifted shall be performed immediately before placing personnel in the platform. A proof test of 125% of the rated capacity of the platform must be held for 5 minutes. This may be done in conjunction with the trial lift.

A body harness and shock absorbing lanyard shall be worn and attached to a structural member within the personnel platform capable of supporting the impact from a fall. The harness and anchorage system shall conform to OSHA requirements.

Tag lines shall be used unless their use creates an unsafe condition. Hoisting of the personnel platform shall be performed in a slow, controlled, cautious manner with no sudden movements of the crane. Personnel shall keep all parts of the body inside the platform during raising, lowering, and positioning.

Before personnel exit or enter a hoisted platform that is not landed, the platform shall be secured to the structure where the work is to be performed, unless securing to the structure creates an unsafe situation.

#### Personnel Lift Requirements

- allowed only when no safer method is available
- equipment conforms to 29 CFR 1926.1431 and ASME B30.23
- the total load less is than 50% of the rated capacity of the hoist
- trial lift of anticipated load or greater
- proof test of 125% of rated platform capacity
- tools and materials
  - weight included in load
  - evenly distributed
  - secured
- fall protection used with full body harness and shock absorbing lanyard attached to platform structure
- tag lines used
- keep body inside platform
- secure platform to structure before:
  - entering
  - exiting



---

---

---

---

---

---

---

---

### Lift Requirements for Lifts Over 80% Capacity

Lifts exceeding 80% of the certified capacity of the crane's hoist planned for use (lifts exceeding 50 percent of the hoist capacity for a mobile crane mounted on a barge) are considered complex lifts.

Use a larger capacity hoist, if possible, to avoid exceeding 80% of capacity.

---

---

---

### Submerged Lifts

Lifts of submerged or partially submerged objects are complex lifts. The following lifts are not considered complex: Removal of valves, rotors, pipes, etc., from dip tanks for cleaning or coating purposes; lifting boats from the water if the boats are of open design with bilge compartments accessible for visual inspection; the boats have label plates indicating weights; and the boats have pre-determined lifting points established by the Original Equipment Manufacturer or the activity engineering organization; lifting submerged or partially submerged objects that meet the following criteria: the object is verified to not contain fluid in pockets and/or voids that is unaccounted for in the weight of the object; the object is verified or known to not be stuck by suction or adhesion by corrosion, marine growth, excessive surface tension, mud etc.; and the object is verified to be clear of obstructions such as other objects in the water, or underwater cables.

### Lifts over 80% of Capacity



- Lifts exceeding 80% of the certified capacity of the crane's hoist planned for use are complex lifts.

### Submerged Lifts

#### Complex Lifts:

- lifts of submerged or partially submerged objects

#### Non-Complex Lifts:

- lifts from dip tanks or lifts of boats or submerged objects of known weights where bilges or compartments are accessible for visual inspection, verified to not contain fluids, and clear of obstructions



---

---

---

---

### Lift Requirements for Multiple Crane Lifts

Multiple-crane or multiple-hook lifts on the same crane, except for bridge or gantry cranes with hooks mechanically/structurally coupled together or control systems electrically/electronically connected, and specifically designed for simultaneous lifting such as jet engine test stand lifting cranes or synchronized antenna lifting cranes are complex lifts. These lifts require special planning, coordination, and skill.

The weight of the load and the weight carried by each crane and hook must be determined prior to the lift to avoid overloading of the cranes and/or rigging gear. One signal person must be assigned to direct and control the entire operation.

---

---

---

### Constrained Loads

Lifts of constrained or potentially constrained loads (a binding condition) including suction caused by hydraulic conditions and loads that may be frozen to the ground are complex lifts.

Where overloading, loss of load (slack line condition) of the crane or rigging, or damage to the load is possible due to binding conditions or pre-tensioning, a portable LID with a readout readily visible to the signal person or RIC shall be used. When an LID is used, an appropriate stop point shall be established and the LID shall be carefully monitored to ensure the stop point is not exceeded.

Chainfalls or other control means (for example procedures, micro-drives, load position/buffer) shall be used to avoid sudden overload of the crane or rigging gear. These lifts shall be treated as complex lifts.

### Lift Requirements for Multiple Crane or Hook Lifts

**Require:**

- planning
- coordination
- skill

**Needed Information:**

- accurate load weight
- capacities for each crane
- load on each crane

**Communication:**

- clear
- constant
- one person provides direction



### Constrained Loads



**Complex Lifts:**

- lifts of constrained or potentially constrained loads
- Where overloading the crane or rigging is possible, a load-indicating device shall be used.
- When necessary, chainfalls should be used to avoid sudden overload.

---

---

---

---

### Other Lifts

Other complex lifts include lifts of unusually expensive or one-of-a-kind equipment or components and lifts involving non-routine operations, difficult operations, sensitive equipment, or unusual safety risks.

---

---

---

### Summary

There are two types of lifts: Complex and Non-complex. Complex lifts have a moderate to high level of risk involved. All complex lifts require preplanning, written procedures, and supervisory oversight. Complex lift exceptions include lifts by certain smaller cranes used primarily to service only one work area, cranes designed for simultaneous lifting, load tests, and ordnance lifts covered by NAVSEA OP-5 except for lifts exceeding 80 percent of the capacity of the crane's hoist, lifts using tilt fixtures, lifts where binding may occur, lifts of submerged loads, and multiple crane or multiple hook lifts.

---

---

---

### Other Complex Lifts

- lifts of unusually expensive or one-of-a-kind equipment or components
- lifts involving non-routine operations, difficult operations, sensitive equipment, or unusual safety risks



### Complex and Non-Complex Lifts Summary

#### Two types of lifts:

- Complex
- Non-Complex

#### Non-Complex lifts:

- ordinary in nature
- oversight not required
- directed by a rigger-in-charge

#### Complex lifts:

- moderate to high level of risk
- require:
  - preplanning
  - written procedures
  - supervisory oversight

Knowledge Check

5. **Select the best answer.** Which of the following identifies the two basic categories of crane lifts?
- A. Common and Uncommon
  - B. Complex and Non-Complex
  - C. Critical and Non-Critical
  - D. Usual and Unusual
6. **Select the best answer.** Personnel lifts are—
- A. always considered complex lifts
  - B. considered complex only under special conditions
  - C. not considered complex if personal protective gear is worn
  - D. not considered complex if personnel lifting devices are used
7. **Select the best answer.** Personnel in a man-lift platform or basket must—
- A. stand with knees bent to absorb motion shock
  - B. wear a full body harness with a shock absorbing lanyard
  - C. wear a safety belt with a shock absorbing lanyard
  - D. wear aircraft reflective tape on their hard hat
8. **Select the best answer.** For personnel lifts, the total load must not exceed—
- A. 50% of the hoist's rated capacity
  - B. 80% of the hoist's rated capacity
  - C. the gross capacity if designated as a complex lift
  - D. the load chart capacity

## **CRANE COMMUNICATIONS**

### Welcome

Welcome to Crane Communications.

---

---

---

### Learning Objectives

Upon successful completion of this module, you will be able to describe the communication methods used during crane operations at Navy facilities including hand signals, radio communications, and direct voice.

---

---

---

### Crane Communication Methods

Standard hand signals provide a universal language understood by everyone involved with weight handling; consequently, they are the most common method used in crane operations. When presented properly, standard hand signals help prevent miscommunication and play a very important part in safe crane operations.

When making lifts where hand signals are not feasible (such as when the operator cannot see the signal person), the rigger giving the signals shall remain in continuous voice communication with the operator. The operator shall stop the crane at any time and in any situation judged to be unsafe or when communication is lost or unclear. If communication is lost, the operator shall stop operation until communication is reestablished. In



### Learning Objectives

Upon successful completion of this module, you will be able to:

- Describe communication methods
- Use and interpret hand signals
- Explain radio proper procedures
- Explain when direct voice is allowed

### Crane Communication Methods

- Hand signals
- Radio communications
- Direct voice
- Continuous communications required for:
  - Complex lifts
  - Blind lifts
- Use direct voice only in close proximity

---

---

---

addition, the operator shall immediately respond to a direction from any person to stop the crane.

Radio communications are well suited for blind and complex lifts. As a general rule, direct voice should only be used when the operator and rigger are working in close proximity, and ambient noise is not a factor.

### Hand Signals

Hand signals are the most widely used method of communication between signalers and crane operators. Hand signals like those found in the American Society of Mechanical Engineers, A.S.M.E. B30 standards, must be posted in the crane in clear view of the operator. Your activity may approve local signals in addition to these standard signals.

---

---

---

### Hand Signal Rules

Signalers must remain in clear view of the crane operator. If the crane operator can't see you, another method of communication must be used. Only one rigger or signaler shall communicate with the crane operator at a time except for the stop and emergency stop signals which may be given at any time by any team member.

---

---

---

---

---

---

---

**Hand Signals**

**Standard Signals Source:**

- Standard Hand Signals from The American Society of Mechanical Engineers (A.S.M.E. B30)

**Additional hand signals, must be:**

- approved by crane and rigger supervisors
- included in rigger and operator training
- posted in the crane cab in clear view

**Relay Signalers:**

- from signaler to signaler to the operator
- results in lag time
- not more than two signalers
- not recommended for close tolerance lifts
- requires positive transfer of load control



**Hand Signal Rules**

- Signalers must remain in clear view of the operator.
- Only one signaler shall communicate with the crane operator at a time.
- Stop and emergency stop signals may be given by any team member.

## Radio

Radios can be used to direct crane lifts while keeping crane team members informed of the lift status.

Radio guidelines: The device or devices used shall be tested on-site prior to crane operations. Use an isolated channel and clear the line of other traffic. Limit background noise. The operator's reception of signals shall be by a hands-free system.

Radio work practices: Voice directions given to the operator shall be given from the operator's directional perspective. Identify the crane and yourself. Each voice signal shall contain the following elements, given in the following order: function (such as hoist, boom), direction, distance and/or speed, function, stop command. Allow time between commands. Verify the command. Note: The operator shall stop the crane at any time and in any situation judged to be unsafe or when communication is lost or unclear. In addition, the operator shall immediately respond to a direction from any person to stop the crane.

### Radio Communications

- The device(s) used shall be tested on-site prior to operations.
- Use an isolated channel
- Clear the line of other traffic
- Limit background noise
- The operator's reception of signals shall be by a hands-free system.
- Voice directions given to the operator shall be given from the operator's directional perspective.
- Identify the crane and yourself
- Each voice signal shall contain the following elements, given in the following order: function (such as hoist, boom), direction, distance and/or speed, function, stop command.
- Allow time between commands
- Verify the command



**Note:** The operator shall stop the crane at any time and in any situation judged to be unsafe or when communication is lost or unclear. In addition, the operator shall immediately respond to a direction from any person to stop his/her crane.

---

---

---

---

---

## Knowledge Check

- 1. Select the best answer.** Direct voice should only be used when—
  - A. no other form of communication is available, and ambient noise is high.
  - B. the operator and rigger are working in close proximity and ambient noise is high.
  - C. the operator and rigger are working in close proximity and ambient noise is low.
  - D. the rigger has not learned hand signals.
- 2. Select the best answer.** In the crane cab, the crane operator must have a clear view of the—
  - A. ASME Hand Signal Chart
  - B. crane lift history
  - C. crane maintenance records
  - D. EOM
- 3. Select the best answer.** How many signalers shall communicate with the crane operator at the same time?
  - A. no signalers unless directed by the Rigger-in-Charge
  - B. one signaler at a time
  - C. one signaler for each crane involved
  - D. up to three signalers



4. **Select the best answer.** A universal language understood by everyone involved with weight handling is—
- A. direct voice commands
  - B. hand signals
  - C. signal flags
  - D. spoken word
5. **Select the best answer.** Any additional hand signals must be—
- A. approved by ASME
  - B. approved by NOSH
  - C. approved by OSHA
  - D. approved by the activity
6. **Select the best answer.** Another form of communication, other than hand signals, must be used if—
- A. activities designate alternative methods.
  - B. ambient noise is greater than the lack of visibility.
  - C. the signaler is in clear view of the Rigger-in-Charge.
  - D. the signaler is not in clear view of the crane operator.

### Hook and Trolley Signals

These signals indicate which hook or trolley to use and are used in conjunction with operating signals.

---



---



---

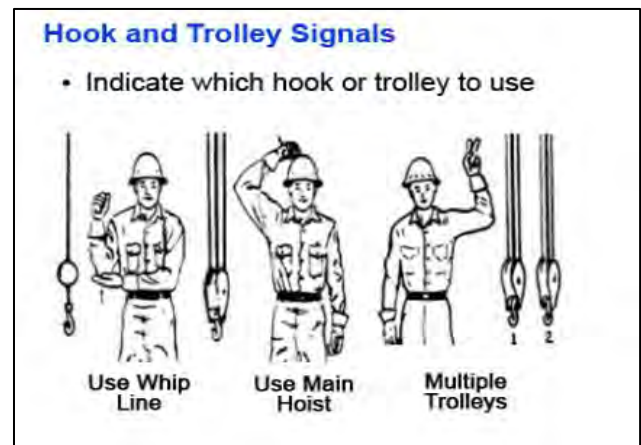

### Auxiliary Hoist

When calling for the whip line or auxiliary hoist, the elbow is tapped with the opposite hand and followed with the appropriate hook movement signal.

---



---



---



### Main Hoist

When calling for the main hoist, the signaler taps a fist on his or her hard hat and follows with the appropriate hook movement signal.

---

---

---

### Multiple Hook & Trolleys

When working with a multiple trolley crane, these signals indicate which trolley to use. They are always followed by movement signals.

---

---

### Hoist Signals

Hoist and lower signals are the same for all cranes. The distinct circular motion helps the operator see the signal clearly from greater distances and helps distinguish them from other signals.

---

---

### Hoist Up

The hoist signal is given with the forearm vertical, the index finger pointing up, and the hand moving in small horizontal circles.

---

---

#### Main Hoist



- The fist is tapped on the hard hat to indicate the main hoist.
- Followed up with standard hook signals

#### Multiple Hooks or Trolleys

- One finger up for the number "1" hook or trolley
- Two fingers up for the number "2" hook or trolley
- Each followed with standard signals to indicate the desired motion



#### Hoist and Lower Signals

- Used with all cranes
- Signals "hoist" or "lower"
- Circular motion adds clarity

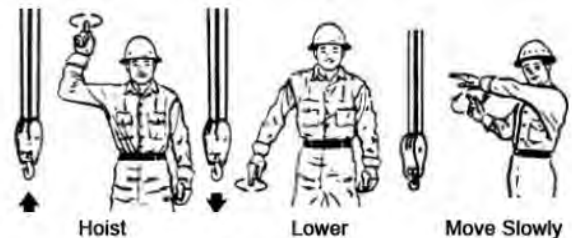

#### Hoist

- Forearm raised
- Index finger pointing up
- Hand moving in small horizontal circles



### Hoist Lower

The lower signal is given with the arm extended downward, the index finger pointed down, and the hand moving in small horizontal circles.

---



---



---

**Lower**

- Arm extended downward
- Index finger pointed down
- Hand moving in small horizontal circles



Lower

### Move Slowly

A hand held motionless in front of any signal indicates to move slowly. In this clip, the rigger is signaling to hoist slowly.

---



---

**Move Slowly**

- A hand held in front of any signal indicates to “move slowly.”
- One hand gives a signal.
- The other hand is motionless in front of the signal.



### Boom Signals

Boom signals direct the operator to raise and lower or to extend and retract the boom. Combination boom and hoist signals allow the load to remain at the same height while booming up or down.

---



---

**Boom Signals**

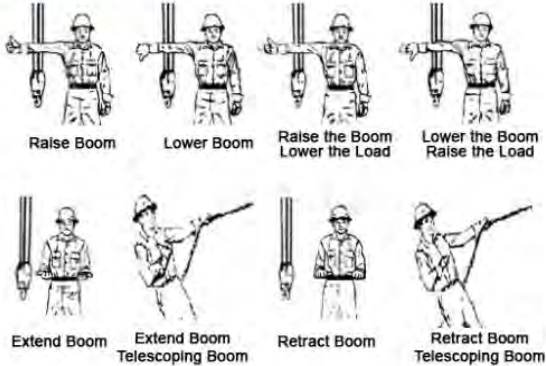

Raise Boom    Lower Boom    Raise the Boom  
Lower the Load    Lower the Boom  
Raise the Load

Extend Boom    Extend Boom  
Telescoping Boom    Retract Boom    Retract Boom  
Telescoping Boom

### Raise Boom (Boom Up)

The signal to raise the boom, or boom up, is given with an extended arm, fingers closed, and thumb pointing upward.

---



---

**Raise Boom (Boom Up)**

- Arm extended
- Fingers closed
- Thumb pointing up



### Lower Boom (Boom Down)

The signal to lower the boom or boom down is given with an extended arm, fingers closed, and thumb pointing downward.

---

---

#### Lower Boom (Boom Down)

- Arm extended
- Fingers closed
- Thumb pointing down



### Raise the Boom – Lower the Load

The signal to raise the boom and lower the load is given with an extended arm, thumb pointing upward, and fingers flexing in and out.

---

---

#### Raise Boom and Lower Load

- Arm extended
- Thumb pointing up
- Flexing fingers in and out



### Lower the Boom – Raise the Load

The signal to lower the boom and raise the load is given with an extended arm, thumb pointing downward, and fingers flexing in and out.

---

---

#### Lower Boom and Raise Load



- Arm extended
- Thumb pointing down
- Flexing fingers in and out

### Extend Boom

The signal to extend the boom is made with both fists in front of the body and thumbs pointing outward away from each other, motioning in and out.

---

---

#### Extend Telescoping Boom

- Both fists in front of the body
- Thumbs pointing out
- Motioning in and out



### Extend Boom One Handed

The one handed extend signal is made with one fist in front of the chest and the thumb pointing inward with a tapping motion.

---

---

### Retract Boom

The signal to retract the boom is made with both fists in front of the body, thumbs pointing toward each other and motioning in and out.

---

---

### Retract Boom One Handed

The one handed retract signal is made with one fist in front of the chest and the thumb pointing outward with a tapping motion.

---

---

#### Extend Boom - One Hand



- Place one fist in front of the chest
- Thumb pointing inward
- Show a tapping motion

#### Retract Boom

- Fists in front of the body
- Thumbs pointing toward each other
- Motioning in and out



#### Retract Boom - One Handed Signal

- Place one fist in front of the chest
- Thumb pointing out
- Show a tapping motion



### Directional Signals

Directional signals are used to guide horizontal crane movements such as bridge, trolley, and swing.

---

---

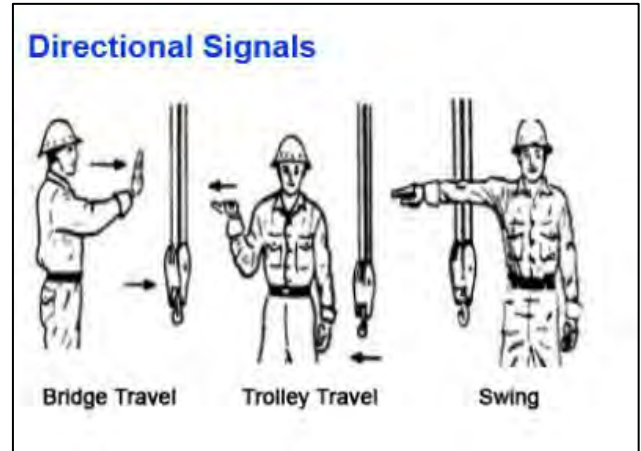

### Travel or Bridge

The signal for crane or bridge travel is made with an extended arm, hand open with palm facing outward, and the hand moving horizontally in the desired direction of travel.

---

---

**Travel or Bridge**



- An extended arm
- Hand open and palm facing outward
- Hand moving horizontally in desired direction of travel

### Trolley Direction

The signal for trolley travel is made with a palm up and fingers closed and the thumb moving in the desired direction of travel.

---

---

**Trolley**



- Hand held with fingers closed
- Thumb pointing in the desired direction of travel
- The extended thumb moves in the direction of travel

### Swing

The signal for swing or rotate is an extended arm with the index finger pointed in the desired direction of rotation.

---

---

**Swing**

- Arm extended
- Hand closed
- Index finger pointing in the desired direction of swing



### Stop Signals

Stop and emergency stop signals can be given by anyone. When these signals are given, the operator must stop operations as quickly and as safely as possible. The dog everything signal is used when all operations must be secured.

---

---

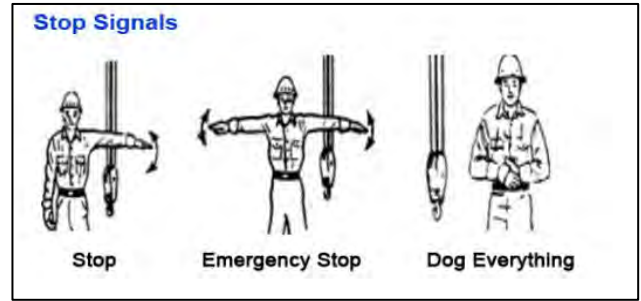

### Stop

The stop signal is an extended arm, palm down moving back and forth horizontally.

---

---

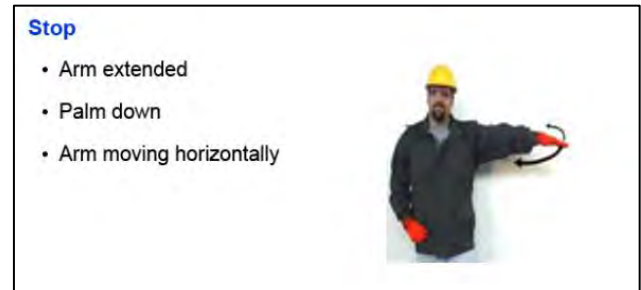

### Emergency Stop

The signal for an emergency stop is both arms extended with palms down, moving them back and forth horizontally.

---

---

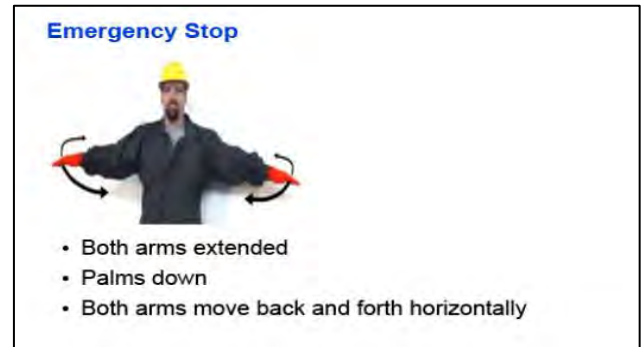

### Dog Everything

The signal to dog everything is given to the operator when crane operations are complete or when the crane needs to be secured. The signal to dog everything is clasped hands in front of the body.

---

---

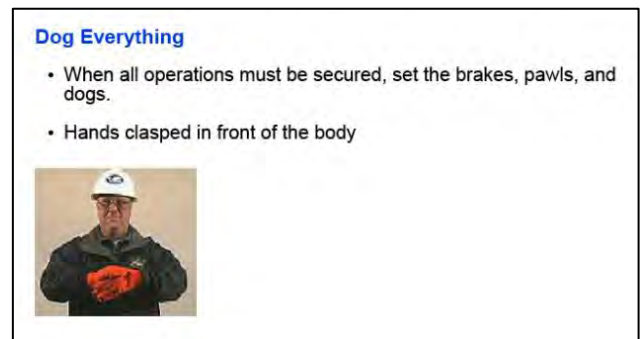

### Magnet Signals

Magnet signals are used to communicate the current status of the magnet whether it is on or off.

---

---

### Magnet Disconnected

The magnet disconnect signal is used to let the person on the ground know that the electricity has been secured and it is safe to disconnect the magnet from the crane. The magnet disconnected signal is given with both arms extended, palms up, and fingers open.

---

---

### Communications Summary

In order for communications to be effective, they must be clear, concise, continuous, and understood by the crane team. Hand signals are the primary means of communication between signalers and operators. Radios are preferred for complex and blind lifts. Voice communication should only be used in close proximity and where ambient noise is not a problem.

---

---

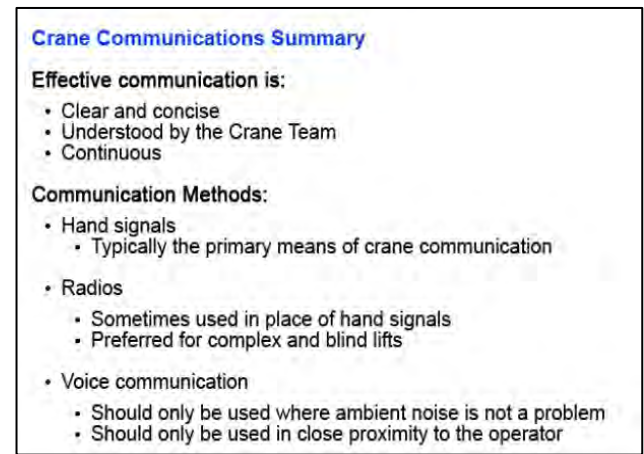
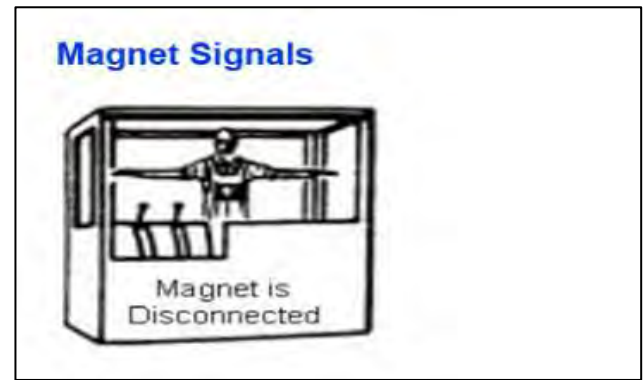



Knowledge Check

7. **Select the best answer.** This signal indicates to—

- A. raise hoist
- B. travel
- C. use auxiliary hoist
- D. use main hoist



8. **Select the best answer.** When the signalers fingers are flexing in and out, this signal indicates to—

- A. lower the boom
- B. lower the hoist
- C. raise the load-lower the boom
- D. stop activities



9. **Select the best answer.** This signal indicates to—

- A. extend the boom
- B. forward
- C. raise the load
- D. stop



10. **Select the best answer.** This signal indicates to—

- A. lower the load
- B. move closer
- C. retract the boom
- D. separate the load



11. **Select the best answer.** This signal indicates to—

- A. emergency stop
- B. stop
- C. swing
- D. travel back



12. **Select the best answer.** This signal indicates to—

- A. emergency stop
- B. magnet disconnect
- C. stop
- D. swing



13. **Select the best answer.** This signal, given by the operator, indicates—

- A. emergency stop
- B. magnet disconnected



14. **Select the best answer.** This signal, given by the operator, indicates—

- A. dog everything
- B. emergency stop
- C. lower load
- D. retract boom



15. **Select the best answer.** What is the bridge crane communications hand signal pictured with the palms up, fingers closed, thumb pointing in the direction of motion and jerking horizontally?

- A. bridge travel
- B. hoist
- C. move slowly
- D. swing
- E. trolley travel



16. **Select the best answer.** What is the crane communication hand signal pictured with the arm extended forward, hand open and slightly raised making a pushing motion?

- A. bridge travel
- B. hoist
- C. lower
- D. move slowly
- E. trolley travel



17. **Select the best answer.** This signal, given by the operator, indicates—

- C. emergency stop
- D. magnet disconnected



18. **Select the best answer.** This signal, given by the operator, indicates—

- E. dog everything
- F. emergency stop
- G. lower load
- H. retract boom



19. **Select the best answer.** What is the bridge crane communications hand signal pictured with the palms up, fingers closed, thumb pointing in the direction of motion and jerking horizontally?

- F. bridge travel
- G. hoist
- H. move slowly
- I. swing
- J. trolley travel



20. **Select the best answer.** What is the crane communication hand signal pictured with the arm extended forward, hand open and slightly raised making a pushing motion?

- F. bridge travel
- G. hoist
- H. lower
- I. move slowly
- J. trolley travel



## CRANE TEAM CONCEPT

### Welcome

Welcome to Crane Team Concept.

---

---

---

### Learning Objectives

Upon successful completion of this module, you will be able to explain the crane team concept, define how a crane team is organized, and understand the roles and responsibilities of each team member.

---

---

---

### Crane Team Concept

The crane team concept was developed to help ensure that crane operations are executed without injury to personnel and without damage to property or equipment. To accomplish this goal, the crane team works together to identify and eliminate obstacles to safety.

---

---

---



**Welcome**

Welcome to Crane Team Concept.

Begin

### Learning Objectives

Upon successful completion of this module, you will be able to:

- Explain the crane team concept
- Define crane team organization
- Identify team member responsibilities



### Crane Team Concept

- The Crane Team Concept helps ensure crane operations:
  - Without injury to personnel
  - Without damage to:
    - Property
    - Equipment



## Crane Team Members

The basic crane team consists of the crane operator and the rigger-in-charge. The supervisor may assign other personnel as required. Additional members may include riggers, signal persons, and crane walkers. A rigger supervisor, operator supervisor, or a rigging or crane operator working leader may conduct team briefings.

---

---

---

### Team Members

- The basic crane team members include:
  - the crane operator
  - Rigger-In-Charge
- Additional team members may include:
  - riggers
  - signal persons
  - crane walkers

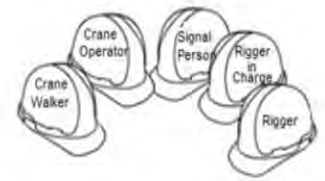

## Knowledge Check

1. **Select the best answer.** The Crane Team Concept was developed to ensure that all operations involving the crane are executed without—
  - A. damage to equipment
  - B. damage to property
  - C. injury to personnel
  - D. all of the above
2. **Select the best answer.** The minimum Crane Team consists of—
  - A. the crane operator and rigger-in-charge
  - B. the crane operator, crane supervisor, and crane rigger
  - C. the crane operator, crane walker, and crane rigger
  - D. the crane operator, rigger, supervisor, and crane rigger
3. **Select the best answer.** Additional crane team members may be assigned by—
  - A. the crane operator as required
  - B. the crane rigger as required
  - C. the EOM designation
  - D. the supervisor as required

### Shared Responsibilities

While each member of the crane team has individual responsibilities, all team members share some common responsibility, including participation in pre-job briefings, watching for potential problems and making other team members aware of them.

All team members are responsible for keeping nonessential personnel away from the crane's operating envelope during lifting evolutions. Any crane team member shall stop the job any time unsafe conditions are found and report to supervision problems that cannot be resolved by the team.

---

---

**Shared Responsibilities**

Crane Team shared responsibilities include:

- Pre-job briefing
- Communications
- Safety



### Pre-Job Briefing

A rigger supervisor, operator supervisor, or a rigging or crane operator working leader (classified as WL) shall review on-site conditions for complex lifts and shall perform a pre-job briefing before each complex lift to ensure all crane team personnel understand the required procedures for the lift.

Any newly assigned personnel shall be briefed by the supervisor or working leader.

---

---

**Pre-Job Briefing**



- A rigger supervisor, operator supervisor, or a rigging or crane operator working leader shall review on-site conditions for complex lifts and shall perform a pre-job briefing before each complex lift.
- Any newly assigned personnel shall be briefed by the supervisor or working leader.

### Communications

Communications during the lift are just as important as the pre-lift brief. All team members must be made aware of any problems that are discovered. When making lifts where hand signals are not feasible, the rigger giving the signals shall remain in continuous voice communication with the operator. If the communication ceases, the operator shall stop operation until communication is reestablished.

---

---

**Crane Team Communications**

When making lifts where hand signals are not feasible:

- The rigger giving signals shall remain in continuous voice communication with the operator.
- If communication is lost, the operator shall stop until communication is reestablished



### Safety

**Stop crane operations** before personnel board the crane. Cranes should be positioned to allow safe boarding.

**Stop work** if you're unsure about the assigned task or, if you feel safety is in jeopardy. Have problems resolved before resuming operations.

---

---

---

### Crane Operator Responsibilities

The crane operator must ensure that his or her license is not expired and that the certification of the crane is not expired prior to operation. These are the two expiration dates that are of particular importance to crane operators.

The crane operator is responsible for performing the pre-use check of the crane, and the operator's main concern during crane operation is operating safely. The crane operator must have a full understanding of each lift prior to execution and moves only when directed by the signal person.

---

---

### Pre-Use Check

When performing the pre-use check of the crane, the operator follows and completes the Operator's Daily Checklist, the ODCL.

---

---

---

#### Crane Team Safety

Team members must stop operations when:

- Safety is jeopardized.
- Personnel board the crane.
- The task is not clear.



#### Crane Operator Responsibilities

Crane operators are responsible for:

- the pre-use check
- understanding the lift
- operating safely



#### Pre-Use Check



The ODCL includes:

- Walk Around Check
- Machinery House Check
- Operator's Cab Check
- Operational Check

### Full Understanding of the Lift

Before making a lift, the crane operator must have a full understanding of the lift and how it is to be executed. The operator must know the exact or estimated load weight, the destination, and the capacity of the crane as it is configured.

---

---

---

**Full Understanding**

**Lift variables:**

- Load weight
- Load destination
- Crane capacity



### Stopping Operations

The crane operator must immediately stop operations when the operating envelope is penetrated, if communications are lost during a blind or complex lift, and anytime a stop signal is given by anyone.

---

---

---

**Stopping Operation for Safety**

**The crane operator stops operations when:**

- A vehicle or pedestrian enters the crane envelope.
- Communications are lost.
- A stop signal is given.



### Knowledge Check

4. **Select the best answer.** While the members of the crane team have individual responsibilities, each have joint responsibilities as well. Each member must—
- A. attend the pre-lift briefing. Any new members who replace another team member must be briefed as well.
  - B. keep nonessential personnel out of the operating area
  - C. keep the rigger-in-charge well informed of conditions affecting personnel or the equipment during lifts
  - D. perform all of the actions listed above
  - E. stop operations whenever safety is in question
  - F. support the goal of safe crane operation
5. **Select the best answer.** Securing the crane envelope is the—
- A. combined responsibility of all team members
  - B. combined responsibility of the crane operator and the crane supervisor
  - C. sole responsibility of the crane operator
  - D. sole responsibility of the rigging supervisor



6. **Select the best answer.** Crane operators are responsible for all the following **except**—
- A. doing a thorough ODCL inspection
  - B. lifting and landing all loads safely
  - C. maintaining communication with the signaler
  - D. slowing down when signals are unclear
7. **Select the best answer.** If you feel safety is in jeopardy during the performance of your task, you should—
- A. call your supervisor for clarification
  - B. evaluate the lift plan
  - C. stop work and have the problem resolved
  - D. use the OEM manual to solve the problem
8. **Select all that apply.** The crane operator must immediately stop operations when—
- A. a stop signal is given
  - B. communications are lost during a blind or complex lift.
  - C. operations have exceeded allowed time
  - D. the operating envelope is penetrated
  - E. the weather forecast is not good.

### Rigger-In-Charge Responsibilities

The rigger-in-charge (RIC) has overall control of the operation including planning all aspects of the lift, determining the weight of the load to be lifted, establishing the appropriate method of communication with the operator, ensuring the load is properly rigged, ensuring the crane operating envelope remains clear of all obstructions, providing signals to the operator or assigning another rigger or signal person to provide the signals, and conducting the operation in a safe manner.

The RIC shall coordinate the activities of other crane team members. The RIC shall not perform functions that would compromise his or her overall control of the operation.

---

---

---

**Rigger-In-Charge Responsibilities**

- Planning all aspects of the lift
- Determining the load weight
- Establishing the method of communication
- Ensuring the load is properly rigged
- Ensuring the crane operating envelope remains clear of all obstructions
- Providing signals to the operator
- Conducting the operation in a safe manner
- Coordinating the activities of other team members



### Rigger Responsibilities

The rigger is responsible for carrying out the assignments from the rigger-in-charge and the rigger supervisor, including assisting the crane operator in performing the pre-use check of the crane, proper gear selection and inspection prior to use, safe rigging of the load, and keeping the rigger-in-charge informed of questionable conditions associated with the operation.

---

---

---

**Rigger Responsibilities**

- Assisting the crane operator in performing the pre-use check of the crane
- Proper gear selection and inspection prior to use
- Safe rigging of the load
- Keeping the Rigger-In-Charge informed of questionable conditions



### Crane Walker Responsibilities

The crane walker ensures the safe travel of the crane by observing for potential obstructions, properly aligning crane rail switches, and being in a position to immediately notify the operator to stop operations should a potential problem arise. Based on the size of the crane and congestion of the area, multiple crane walkers may be required.

---

---

---

**Crane Walker Responsibilities**

- Observing for potential obstructions
- Properly aligning crane rail switches
- Being in position to notify the operator to stop operations



### Assists with the Pre-Use Check

The crane walker is responsible for assisting the rigger and operator in the pre-use check of the crane.

---

---

---

**Assists with the Pre-Use Check**



### Signal Person Responsibility

The signal person (or designated signaler) is responsible for communicating crane movements with the crane operator. The signal person may be the rigger-in-charge, a rigger, or another qualified individual.

---

---

---

### Supervisor Responsibilities

The supervisor is familiar with NAVFAC P-307 and supports the crane team concept. The supervisor designates crane team personnel, reviews and inspects site conditions for potential safety problems and complex lifts, reviews procedures for operations near electrical lines, investigates and reports crane accidents, and supports the team anytime they feel they need to stop a lift due to safety concerns.

---

---

---

### Site Conditions

A rigger supervisor, operator supervisor, or a rigging or crane operator working leader shall review on-site conditions for complex lifts.

---

---

---

#### Signal Person Responsibility



- Responsible for communicating crane movements
- The signal person may be the RIC, rigger, or other qualified individual.

#### Supervisor Responsibilities

- Designates crane team personnel
- Reviews and inspects site conditions for complex lifts
- Reviews procedures for operations near electrical lines
- Investigates and reports crane accidents

#### Site Conditions

- Supervisors or work leaders review on-site conditions for complex lifts.



### Operation Near Power Lines

The supervisor assesses potential hazards and establishes procedures for safe operations around overhead electrical power lines.

---

---

---

**Power Lines**



- The supervisor reviews procedures for operations near electrical lines.

### Complex Lifts

A rigger supervisor, operator supervisor, or a rigging or crane operator working leader shall review on-site conditions for complex lifts and shall perform a pre-job briefing before each complex lift to ensure all crane team personnel understand the required procedures for the lift. Any newly assigned personnel shall be briefed by the supervisor or working leader.

A rigger supervisor, operator supervisor, or working leader shall personally supervise the following lifts: lifts exceeding 80 percent of the certified capacity of the crane's hoist used for the lift (except for lifts using pillar, pillar jib, fixed overhead hoists, or monorail cranes), multiple hook lifts when the weight of the object being lifted exceeds 80 percent of the certified capacity of any hoist used for the lift, and lifts of ordnance involving the use of tilt fixtures. If the lifts are repetitive in nature, the supervisor or working leader shall be present during the first evolution of the lift with each rigging crew. Subsequent identical lifts by the same crew may be done under the guidance of the rigger-in-charge.

**Complex Lifts**

For complex lifts, the supervisor or working leader:

- Reviews on-site conditions
- Performs pre-job briefs
- Supervises lifts:
  - exceeding 80% of capacity
    - (except for lifts using pillar, pillar jib, fixed overhead hoists, or monorail cranes)
  - exceeding 50% of capacity for mobile cranes mounted on barges
  - multiple hook lifts when the weight exceeds 80% capacity of any hoist
  - lifts of ordnance involving the use of tilt fixtures

---

---

---

---

---

### Accidents

The supervisor shall inspect suspected accident scenes, notify appropriate personnel, and ensure that the accident report is filed.

---

---

---

**Accidents**

- The supervisor investigates and reports accidents.



Knowledge Check

9. **Select the best answer.** If an accident is reported, the preliminary investigation will be performed by the—
- A. crane operator
  - B. crane rigger
  - C. rigger-in-charge
  - D. supervisor
10. **Select the best answer.** Planning the lift route is the responsibility of the—
- A. crane operator
  - B. crane rigger
  - C. crane supervisor
  - D. rigger-in-charge
11. **Select the best answer.** Coordinating the activities of the crane team is the responsibility of the—
- A. activities
  - B. crane operator
  - C. crane rigger
  - D. crane supervisor
  - E. rigger-in-charge

**LOAD CHART REVIEW**

Welcome

Welcome to Load Chart Review.

---



---



---

Learning Objectives

Upon successful completion of this module, you will be able to understand the parts of the load chart, understand the potential consequences of exceeding a crane's rated capacity, determine gross capacity, and calculate net capacity.

---



---



---

Parts of a Load Chart

The load chart usually contains the following parts: rated capacities chart, notes section, range diagram, and a working area diagram.



---



---



---

**Welcome**  
Welcome to Load Chart Review.

Begin

**Learning Objectives**

Upon successful completion of this module, you will be able to:

- Understand the parts of a load chart
- Understand the consequences of overloading
- Determine gross and net capacities

**Parts of a Load Chart**

Radius in Feet	Manual Fly Section Retracted Boom Length in Feet						
	32	33	44	50	56	62	68
12	30,000	47,000	44,000	41,000	38,000		
15	42,000					27,000	25,000
20	31,800					26,500	22,000
25	21,800	21,800	21,700	21,100	20,000	19,000	18,000
30		16,300	15,500	15,500	15,500	15,500	15,500
40			9,000	9,000	9,000	9,000	9,000

**Notes**

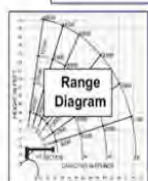
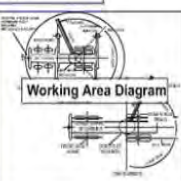
Notes Section

Before calculating the crane’s capacity, the operator must read the general notes found on the load chart or in the load chart package.

Load chart notes contain important information such as deductions from listed capacities, allowable boom lengths, instructions for determining structural vs. stability limitations, wire rope type and reeving information, crane set up requirements, crane configuration requirements for travel and general crane safety reminders.

Load chart notes serve as a safety refresher.

---



---



---

**Notes Section**

- Load Chart Capacity Note**
  - deductions from listed capacity
  - allowable boom lengths
  - instructions for determining **structural VS. stability limitations**
  - wire rope type and reeving information
- crane set up requirements
  - crane configuration requirements for travel
  - general crane safety reminders

surroundings, experience of personnel, handling of load, etc.

Operating radius is the horizontal distance from the axis of rotation to the centerline of the hoist line or tackle with load applied.

"On Rubber" luffing (if permitted) depends on proper tire inflation, capacity, and condition. "On Rubber" loads may be transported at a maximum vehicle speed of 2.5 mi/hr. (4 km./hr.) on a smooth and level surface only.

Power-telescoping boom sections must be extended equally at all times. Long cantilever booms can create a tipping condition when in extended and lowered position.

The maximum load which may be telescoped is limited by hydraulic pressure, boom angle, boom lubrication, etc. It is safe to attempt to telescope any load within the limits of rated luffing capacity chart.

Keep load handling devices a minimum of 12 inches (0.3 meter) below boom head when lowering or extending boom.

Rated Lifting Capacity Chart

The rated capacity chart is that part of the load chart that we reference to determine the crane’s gross capacities. Gross capacities are listed for various boom lengths and load radii.

---



---



---

**Rated Lifting Capacity Chart**

Rated Lifting Capacities in Pounds  
40 FT. - 125FT. Boom  
ON OUTRIGGERS FULLY EXTENDED -360°  
For Training Only

Radius in Feet	BOOM										
	Main Boom Length in Feet										
	40	45	55	65	75	85	95	105	115	125	
10	110,000 (70)	105,000 (72.5)									
12	111,000 (87)	105,000 (75)	94,000 (75)								
16	91,450 (81.5)	81,000 (85.5)	68,250 (70.5)	57,000 (74)							
20	70,500 (82.5)	59,000 (85)	46,000 (86)	35,000 (72.5)	24,000 (75)						
25	55,000 (81.5)	44,000 (85.5)	33,000 (86)	23,000 (88.5)	14,000 (71.5)	11,000 (72.5)	8,000 (73.5)	6,000 (75)	4,500 (75.5)	3,500 (76.5)	2,500 (77.5)
30	42,500 (85)	32,000 (85.5)	22,000 (86)	14,000 (86.5)	9,000 (87)	6,000 (87.5)	4,500 (88)	3,500 (88.5)	2,500 (89)	1,800 (89.5)	1,300 (90)
35	33,000 (86)	24,000 (86.5)	16,000 (87)	10,000 (87.5)	6,500 (88)	4,500 (88.5)	3,500 (89)	2,500 (89.5)	1,800 (90)	1,300 (90.5)	900 (91)
40	26,000 (87)	18,000 (87.5)	12,000 (88)	8,000 (88.5)	5,500 (89)	4,000 (89.5)	3,000 (90)	2,200 (90.5)	1,600 (91)	1,100 (91.5)	800 (92)
45	21,000 (88)	14,000 (88.5)	9,500 (89)	6,500 (89.5)	4,500 (90)	3,500 (90.5)	2,800 (91)	2,100 (91.5)	1,500 (92)	1,100 (92.5)	800 (93)
50	17,000 (88.5)	11,500 (89)	8,000 (89.5)	5,500 (90)	4,000 (90.5)	3,000 (91)	2,400 (91.5)	1,800 (92)	1,300 (92.5)	900 (93)	650 (93.5)
60	12,000 (89)	8,500 (89.5)	6,000 (90)	4,500 (90.5)	3,500 (91)	2,800 (91.5)	2,100 (92)	1,600 (92.5)	1,100 (93)	800 (93.5)	550 (94)
70	9,000 (89.5)	6,500 (90)	4,500 (90.5)	3,500 (91)	2,800 (91.5)	2,100 (92)	1,600 (92.5)	1,100 (93)	800 (93.5)	550 (94)	400 (94.5)
80	7,000 (90)	5,000 (90.5)	3,500 (91)	2,800 (91.5)	2,100 (92)	1,600 (92.5)	1,100 (93)	800 (93.5)	550 (94)	400 (94.5)	300 (95)
100	5,000 (91)	3,500 (91.5)	2,500 (92)	1,800 (92.5)	1,300 (93)	1,000 (93.5)	750 (94)	550 (94.5)	400 (95)	300 (95.5)	200 (96)
150	3,500 (92)	2,500 (92.5)	1,800 (93)	1,300 (93.5)	1,000 (94)	750 (94.5)	550 (95)	400 (95.5)	300 (96)	200 (96.5)	150 (97)
200	2,500 (93)	1,800 (93.5)	1,300 (94)	1,000 (94.5)	750 (95)	550 (95.5)	400 (96)	300 (96.5)	200 (97)	150 (97.5)	100 (98)
250	1,800 (94)	1,300 (94.5)	1,000 (95)	750 (95.5)	550 (96)	400 (96.5)	300 (97)	200 (97.5)	150 (98)	100 (98.5)	75 (99)
300	1,300 (95)	1,000 (95.5)	750 (96)	550 (96.5)	400 (97)	300 (97.5)	200 (98)	150 (98.5)	100 (99)	75 (99.5)	50 (100)
350	1,000 (96)	750 (96.5)	550 (97)	400 (97.5)	300 (98)	200 (98.5)	150 (99)	100 (99.5)	75 (100)	50 (100.5)	35 (101)
400	750 (97)	550 (97.5)	400 (98)	300 (98.5)	200 (99)	150 (99.5)	100 (100)	75 (100.5)	50 (101)	35 (101.5)	25 (102)
450	550 (98)	400 (98.5)	300 (99)	200 (99.5)	150 (100)	100 (100.5)	75 (101)	50 (101.5)	35 (102)	25 (102.5)	15 (103)
500	400 (99)	300 (99.5)	200 (100)	150 (100.5)	100 (101)	75 (101.5)	50 (102)	35 (102.5)	25 (103)	15 (103.5)	10 (104)
600	300 (100)	200 (100.5)	150 (101)	100 (101.5)	75 (102)	50 (102.5)	35 (103)	25 (103.5)	15 (104)	10 (104.5)	5 (105)
700	200 (101)	150 (101.5)	100 (102)	75 (102.5)	50 (103)	35 (103.5)	25 (104)	15 (104.5)	10 (105)	5 (105.5)	3 (106)
800	150 (102)	100 (102.5)	75 (103)	50 (103.5)	35 (104)	25 (104.5)	15 (105)	10 (105.5)	5 (106)	3 (106.5)	2 (107)
900	100 (103)	75 (103.5)	50 (104)	35 (104.5)	25 (105)	15 (105.5)	10 (106)	5 (106.5)	3 (107)	2 (107.5)	1 (108)
1000	75 (104)	50 (104.5)	35 (105)	25 (105.5)	15 (106)	10 (106.5)	5 (107)	3 (107.5)	2 (108)	1 (108.5)	0.5 (109)

Minimum boom angle (deg.) for indicated length (no load) 0°  
Maximum boom length (ft.) up to degrees boom angle (no load) 125°

### Gross Capacity

What can be safely lifted on the hook? To answer this question, we must understand what gross capacity is. Gross capacity is the weight value shown on a manufacturer’s load chart and the maximum amount of weight, per specific configuration, that the crane may lift, prior to deductions. In other words, the gross capacity values found on this chart are not the loads that can be safely lifted on the hook? To answer this question, we must find the net capacity of the crane.

---



---



---

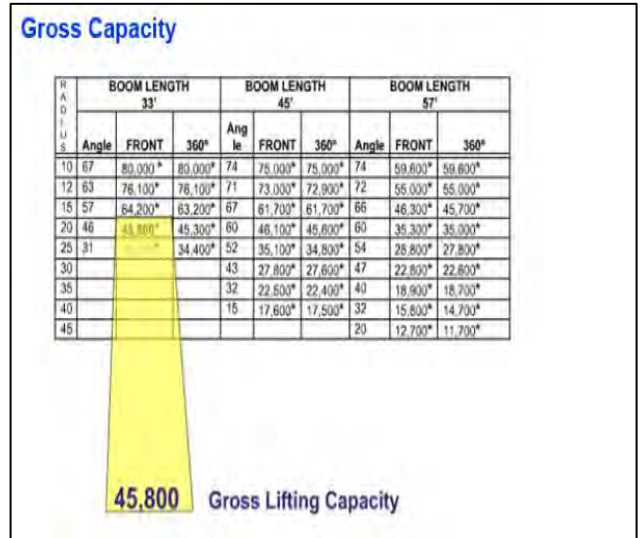

### Net Capacity

Net capacity is the weight value shown on the manufacturer’s load chart, minus all deductions. To calculate net capacity, subtract the effective weight of all deductions from the gross capacity. Common deductions include the weight of hook blocks, headache balls, wire rope, rigging, and attachments such as extensions, swing-away jibs, and auxiliary boom nose sections. Attachments may have different effective weights in the stowed and erected position. The effective weight of these attachments is listed in the load chart notes, in an area titled weight reductions for load handling devices.

---



---



---

**What is Net Capacity?**

Net Capacity:

- The value shown on the manufacturer’s load chart minus all deductions

Common Deductions:

- Weight of Attachments (Stowed and/or Erected)



## Deductions

The weight of attachments, such as swing away jibs, stowed or erected, and the weight of auxiliary boom heads and rooster sheaves, must be deducted from gross capacity. The weight of the hooks, blocks and overhaul ball are also deducted from the gross capacity. The crane may be equipped with standard or optional hook blocks having different weights. Hook block weights and capacities should be stamped on each hook block. Be aware that some manufacturers require the weight of excess wire rope, not necessary for a lift, to be deducted.

---



---



---

## Range Diagram

Range diagrams are used for planning lifts. You can use them to determine the configuration of the crane needed for a particular job. By laying out the geometry of the job on the diagram, the operator can determine the boom length, boom angle, jib length and jib offset required for the lift. When loads must be placed above grade, the boom-tip height must allow for clearance between the boom tip and the load blocks, and the height of the load including the slings. When loads must be set a certain distance in from the edge of a roof, the length of jib and necessary jib offset are easily determined by using the range diagram. It may be used to determine the boom angle of telescopic booms, when the boom is only partially extended, and the radius is known. The range diagram may also be used to identify the allowable clearances between the load blocks and boom tip.

### Common Deductions



**Net Capacity**

- The value shown on the manufacturer's load chart minus all deductions

**Common Deductions**

- Weight of Attachments
  - Stowed and/or Erected
- Weight of Hooks and Blocks
  - Excess wire rope on some cranes

### Range Diagram

Range Diagrams are used to determine:

- Configuration of the crane
- Geometry of the job
- Maximum hook height
- Jib length and offset
- Jib radius and boom angles
- Clearances between the boom tip and hook block

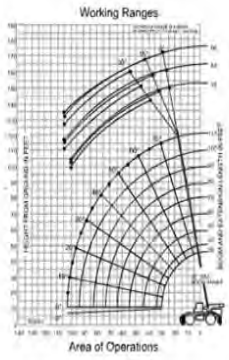

---



---



---

### Working Area Diagram

Another important part of the load chart is the working area diagram. Crane stability and capacity will vary as the load moves from one quadrant of operation to another. Because the crane's capacity is different in each quadrant of operation, it is important to match the load chart to the quadrant, or quadrants, the crane will be working in and through.

---

---

---

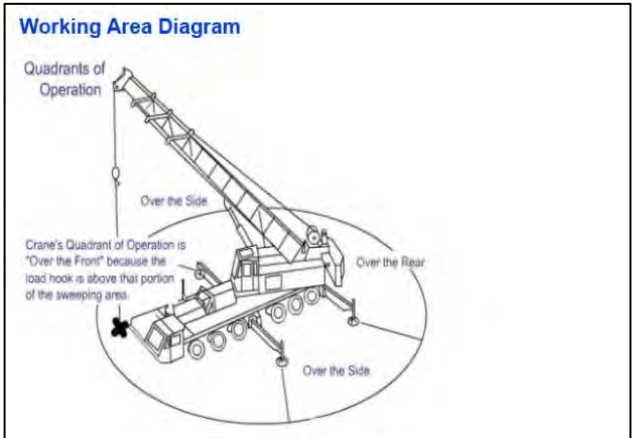

### Category 4 Crane Quadrants of Operations

Category 4 crane stabilizers and operational quadrants vary by manufacturer. Always check OEM documentation for the location of quadrants for your machine. These diagrams provide examples of the different crane and stabilizer placements you may encounter on various category 4 cranes.

---

---

---

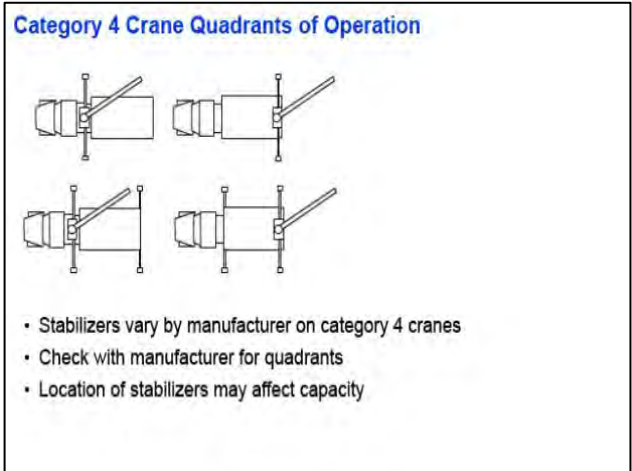

### Consequences of Overloading

Exceeding the crane's rated capacity may result in one of two consequences: loss of stability or structural failure.

---

---

---

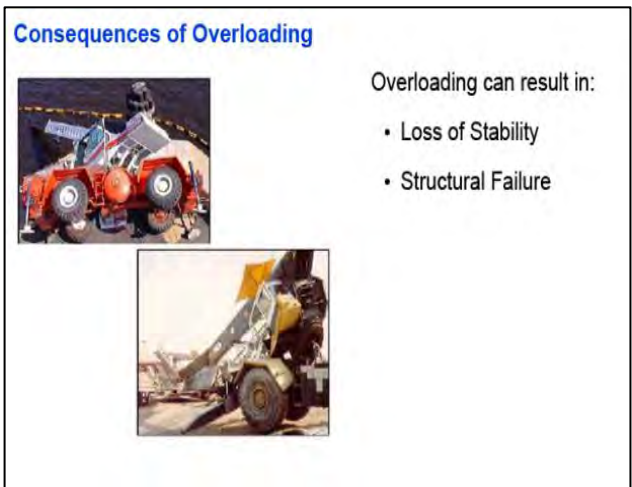

### Loss of Stability

When a crane loses stability, the tipping force of the load overcomes the counteracting load, or counterweight of the crane. When tipping begins, especially with loads high in the air, it's very unlikely that the crane operator can do much to prevent overturning. As the crane begins to tip, the load radius increases; as the load radius increases, the capacity of the crane decreases rapidly. This happens so quickly that recovery is almost impossible.

It is therefore critical for the operator to maintain focus, situational awareness, and a thorough understanding of the crane's capability and capacity in its current configuration.

### Loss of Stability – Telescopic Boom

Loss of stability with telescopic boom cranes can happen more rapidly than other types of cranes because of the increased weight and higher center of gravity of the boom. Many telescopic boom cranes will tip with no load on the hook at all, if the boom angle is too low and the boom is extended too far.

---

---

---

### Loss of Stability - Guessing

Never rely on signs of tipping to determine whether a load can be lifted. This is called operating by the seat-of-the-pants and may result in a catastrophe.

---

---

---

#### Loss of Stability

- As tipping begins, radius increases.
- Increased radius rapidly reduces crane capacity.



#### Loss of Stability: Telescopic Boom Cranes



- Boom raises center of gravity
- Crane can tip without load on the hook!

#### Loss of Stability: Guessing



Never use tipping to determine load weight or crane capacity!

### Structural Failure

If the rated capacity a crane is exceeded, the crane may fail structurally. Structural failure can result in hidden damage such as bent or twisted structural members. Structural failure can occur without warning and result in complete and catastrophic failure. Loss of stability and structural failure from overloading are avoidable if you understand and follow the crane's load chart.

---



---



---

### Finding Gross Capacity

Let's find the gross capacity for a particular lift. In this example, the load will be picked up over the rear quadrant. Capacity may be affected by the quadrant of operation. It's important to select the correct chart for the quadrants in which the lift will be made. In this example, the boom length is 54' and the radius is 45'. First, read down the radius column to 45'. Next, read across to the 54' boom length column to find the gross capacity: 14,840 pounds.

---



---



---

### Deductions

The crane in this exercise is configured with an auxiliary boom head, weighing 143 pounds, a main hook block weighing 895 pounds, a headache ball weighing 560 pounds, and a stowed telescoping extension with an effective weight of 876 pounds.

---



---



---

**Structural Failure**



Structural failure often:

- Happens without warning
- May be catastrophic
- Is avoidable

**Finding Gross Capacity**

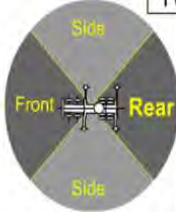

Radius in Feet	ON OUTRIGGERS FULLY EXTENDED						
	Boom Length in Feet						
	34	40	44	54	64	74	84
12	90,000 (70)	70,000 (73)	67,500 (76)	64,000 (76.5)			
15	72,000 (61)	63,700 (65.5)	61,000 (69)	58,000 (73)	44,700 (76)		
20	53,000 (50.5)	52,200 (57.5)	49,800 (62)	44,000 (67.5)	37,900 (71)	35,000 (74)	31,000 (78.5)
25	41,000 (38.5)	41,000 (48)	41,000 (54)	36,300 (61.5)	31,900 (66)	29,200 (70)	27,500 (73.5)
30	29,800 (21.5)	29,800 (37.5)	29,800 (45)	29,800 (56.5)	27,000 (60.5)	25,000 (65.5)	23,900 (69.5)
35		22,800 (23)	22,800 (34.5)	22,800 (43.5)	22,800 (55)	21,800 (61)	20,500 (66)
40			18,090 (19)	18,090 (41)	18,090 (49)	18,090 (56.5)	17,900 (62)
<b>45</b>							<b>14,840 (58)</b>
50							12,330 (53.5)

**Gross Capacity 14,840**

**Common Deductions**

Aux. Boom Head	143 lb.
Main Hook Block	895 lb.
Whip Ball	560 lb.
Stowed Extensions	876 lb.
<b>Total</b>	<b>2,474 lb.</b>



32 ft - 56 ft TELE BOOM EXTENSION	
* Stowed	876
* Erected (Retracted) -	6368
* Erected (Extended) -	8460
Reduction of Main Boom Capacities	
AUXILIARY BOOM HEAD	143 lbs
HOOKBLOCKS AND HEADACHE BALLS	
45 Ton 3 Sheave w/cheekplates	1095
45 Ton 3 Sheave w/o cheekplates	895
50 Ton 4 Sheave	1285
15 Ton 1 Sheave	380
10 Ton Headache Ball	560

### Net Capacity

Finding the net capacity is simply a matter of subtracting the necessary deductions from the listed gross capacity. The gross capacity over-the-rear is 14,840 pounds. The deductions add up to 2,474 pounds. When the deductions are subtracted from the gross capacity, we have a net capacity of 12,366 pounds over-the-rear.

---



---



---

**Calculating Net Capacity**

Subtract deductions from gross capacity:

Gross Capacity	14,840 lbs.
Total Deductions	- 2,474 lbs.
Net Capacity	12,366 lbs.



### Working Between Values

What should you do when the actual load radius, boom length, or boom angle is not listed on the load chart? The following examples show how to find safe lifting capacities when the job requires working between values shown on the load chart.

---



---



---

**Working Between Values**



- What should you do when the actual radius, boom angle, or boom length is not shown on the load chart?

### Load Radius between Values

When the actual load radius falls between the values listed in the capacity chart, use the gross capacity rating for the next longer radius chart listing.

In this example, the load is at a 24-foot radius. The chart shows values in the 20- and 25-foot radius but none at 24 feet.

To find the correct radius, use the value shown on the chart for the longer radius. In this example, the next longer radius is 25 feet.

---



---



---

**Radius Between Values**



- When actual radius is between listed values, use capacity for the next longer radius.

LOAD RATING IN POUNDS								
With Outriggers								
Radius in Feet	Powered Boom Length in Feet							
	33 Feet		45 Feet		57 Feet		69 Feet	
	Angle	Lbs.	Angle	Lbs.	Angle	Lbs.	Angle	Lbs.
12	60	150,000	69	90,000	76	83,000		
15	54	120,000	65	86,000	71	80,000	75	74,000
20	42	90,000	58	74,000	66	67,000	71	60,000
25	25	66,000						50,000
30								43,000
35								37,000

25 Ft. = Next longer radius

### Boom Length

When the actual boom length falls between the values listed in the capacity chart, **use the gross capacity rating for the boom length with the lower capacity listed.**

This example shows the boom length is 36 feet. The chart shows a column for 33- and 45-foot boom lengths. To find the correct capacity, use the column for **the boom length with the lower capacity** shown on the chart.

In this example, the correct column to use is for 45 feet of boom. So, when using a boom length anywhere between 33 and 45 feet, the gross capacity for any load radius, is obtained using the 45-foot column. Some cranes have a slightly higher capacity at a longer boom length for the same radius in some areas of the load chart. In this case, you would choose the capacity of the shorter boom length.

#### Boom Length Between Values

- When actual boom length is between listed values, use the lower capacity.



LOAD RATING IN POUNDS								
With Outriggers								
Radius in Feet	Powered Boom Length in Feet							
	33 Feet		45 Feet		57 Feet		69 Feet	
	Angle	Lbs.	Angle	Lbs.	Angle	Lbs.	Angle	Lbs.
12	60							
15	54					75	74,000	
20	42					71	60,000	
<b>25</b>	25	66,000	50	62,000	60	56,000	66	50,000
30			40	48,000	54	48,000	62	43,000
35			28	37,000	47	37,000	57	37,000

---



---



---

### Between Values for Two Variables

Sometimes you must determine gross capacity for values between those listed for both boom length and radius.

For a 24-foot radius, choose the row for the 25-foot radius. For a 36-foot boom length, read down the column for the 45-foot boom length.

Following this procedure, the gross capacity for both radius and boom length is 62,000 pounds.

Remember, when working between values shown on a capacity chart, **always choose the lower values listed on the load chart to determine safe capacity.**

#### Between Values for Two Variables

- 24 foot radius                      Read 25 feet
- 36 foot boom length              Read 45 feet

LOAD RATING IN POUNDS								
With Outriggers								
Radius in Feet	Powered Boom Length in Feet							
	33 Feet		45 Feet		57 Feet		69 Feet	
	Angle	Lbs.	Angle	Lbs.	Angle	Lbs.	Angle	Lbs.
12	60	150,000	69	90,000	76	83,000		
15	54	120,000	65	86,000	71	80,000	75	74,000
20	42	90,000	58	74,000	66	67,000	71	60,000
<b>25</b>	25	66,000	50	<b>62,000</b>	60	56,000	66	50,000
30			40	48,000	54	48,000	62	43,000
35			28	37,000	47	37,000	57	37,000

Gross Capacity = 62,000 lbs.

**Always choose the lower values shown!**

---



---



---

### Boom Angle Between Values

When the boom angle falls between the values listed in the capacity chart, choose the boom angle with the lower capacity.

In this example, the load will be lifted at a 55° boom angle. As you can see on the capacity chart, 55° falls between the listed angles of 49° and 56°.

To find the correct capacity, choose the row with **the lower capacity** shown on the chart. In this example, the correct reference boom angle is 49°.

---



---



---

#### Boom Angle Between Values



- When actual boom angle is between listed values, use the lower angle.

LOAD RATING IN POUNDS				
MAIN BOOM				
WITH OUTRIGGER FULLY EXTENDED AND SET				
Radius in Feet	Angle in Degrees	Over Front in Pound	Over Rear and Side	Boom Point Elevation (Feet)
25	78		87,970	106
30	75	69,670		
35	72	53,970		
40	69	43,670		
45	66	38,270		
50	63	30,770		
60	56	23,070	23,070	92
70	49	17,970	17,979	84
80	41	14,270	14,270	74

### Knowledge Check

1. **Select the best answer.** The definition of gross capacity is the crane’s lifting capacity—
  - A. after all deductions
  - B. before taking any deductions
  - C. less the weight of everything carried by the outriggers
  - D. plus the weight of everything carried by the outriggers
  
2. **Select the best answer.** The capacity shown on the manufacturer’s load chart is the—
  - A. Gross lifting capacity
  - B. Minimum lifting capacity
  - C. Net lifting capacity
  - D. Overall lifting capacity
  - E. Total lifting capacity
  
3. **Select the best answer.** The two most likely consequences of exceeding the crane’s capacity are loss of stability and—
  - A. bent and damaged rigging gear
  - B. disciplinary action
  - C. motor burn out and failure
  - D. structural failure
  
4. **Select the best answer. True or False:** A telescopic boom crane cannot tip unless there is a load on the hook.
  - A. True
  - B. False

5. **Select the best answer.** A definition of net capacity of—
  - A. the gross capacity less all applicable deductions
  - B. the gross capacity plus all applicable deductions
  - C. the total capacity of all applicable deductions
  - D. the total of the load to be lifted
  
6. **Select the best answer.** If the gross capacity of the crane is 15,000 pounds. And the combined weight of all deductions is 2,800 pounds, the net lifting capacity of this crane is—
  - A. 2,800 pounds
  - B. 12,200 pounds
  - C. 15,000 pounds as found on the manufacturer's load chart
  - D. 18,000 pounds
  
7. **Select the best answer.** When the actual radius, boom angle, or boom length falls between those lifted on the load chart—
  - A. calculate the correct percentage of the difference
  - B. stop and ask your supervisor
  - C. use the higher capacity listed
  - D. use the lower capacity listed
  
8. **Select the best answer.** When planning a mobile crane lift, the operator performs a “dry run” and finds that the radius is 17 feet, and the boom length is 52 feet. Using the sample load chart below, calculate the gross capacity for this scenario.

- A. 48,000 pounds
- B. 56,000 pounds
- C. 67,000 pounds
- D. 74,000 pounds
- E. 80,000 pounds
- F. None of the above

Radius in Feet	LOAD RATING IN POUNDS							
	Over Side and Over Rear With Outriggers							
	Powered boom Length in Feet							
	33 Feet		45 Feet		57 Feet		69 Feet	
	Angle	Lbs.	Angle	Lbs.	Angle	Lbs.	Angle	Lbs.
12	60	150,000	69	90,000	76	83,000		
15	54	120,000	65	86,000	71	80,000	75	74,000
20	42	90,000	58	74,000	66	67,000	71	60,000
25	25	66,000	50	62,000	60	56,000	66	50,000
30			40	48,000	54	48,000	62	43,000
36			28	37,000	47	37,000	57	37,000



## **RIGGING GEAR TEST, INSPECTION, AND MARKING REQUIREMENTS**

### Welcome

Welcome to the Rigging Gear Test, Inspection, and Marking Requirements module.

---

---

---

### Learning Objectives

Upon successful completion of this module, you will be able to explain the primary goal of the test and inspection program, identify the section of NAVFAC P-307 that addresses rigging gear requirements, list the required equipment markings, identify what records must be kept, and identify the equipment covered in Section 14.

---

---

---

### NAVFAC P-307 Section 14

Let's look at the section of NAVFAC P-307 that deals with rigging, Section 14. Section 14 provides selection, maintenance, inspection, test, and use requirements for rigging gear and miscellaneous lifting equipment. These requirements help ensure the rigging gear you use is safe. When followed, these requirements help ensure optimum service life of the gear.

These requirements apply to covered equipment used, with or without cranes, in weight handling operations and to covered equipment used with multi-purpose machines, material handling equipment or "MHE" (e.g., forklifts), and equipment covered by NAVFAC P-300. These requirements also apply to contractor-owned rigging equipment used with Navy and BOS contractor-



**Welcome**

Welcome to the Rigging Gear Test, Inspection, and Marking Requirements module.

Begin

### Learning Objectives

Upon successful completion of this module, you will be able to:

- Explain the primary goal of the P-307 test and inspection program
- Identify the section of NAVFAC P-307 that addresses rigging gear requirements
- List required equipment markings
- Identify what records must be kept
- Identify equipment covered in NAVFAC P-307 Section 14

### NAVFAC P-307 Section 14

- Section 14 provides selection, maintenance, inspection, test, and use requirements for rigging gear and miscellaneous lifting equipment.
- These requirements apply to covered equipment used, with or without cranes, in weight handling operations.
- They also apply to covered equipment used with multi-purpose machines, MHE and equipment covered by NAVFAC P-300.
- These requirements also apply to contractor-owned rigging equipment used with Navy and BOS contractor-owned WHE, multi-purpose machines, MHE, and equipment covered by NAVFAC P-300 used in weight handling operations.

owned WHE, multi-purpose machines, MHE, and equipment covered by NAVFAC P-300 used in weight handling operations.

---

---

---

---

Except for BOS contracts, these requirements do not apply to contractor-owned equipment used with contractor-owned cranes, multi-purpose machines, MHE, backhoes, excavators, and front-end loaders.

### The Test and Inspection Program

NAVFAC P-307 requires each activity to establish a program that includes initial visual inspection and load test of equipment, marking, pre-use inspections before equipment is used, documented periodic inspections of equipment, and documented periodic load tests of certain equipment.

Except for hooks, rigging hardware and load indicating devices do not require load tests or documentation of inspections.

---

---

---

**The Test and Inspection Program**

- Required by NAVFAC P-307
- Program must include:
  - Initial inspections
  - Load tests
  - Marking
  - Pre-use inspections
  - Documented periodic test & inspections
- Except for hooks, rigging hardware and load-indicating devices do not require load tests or documentation of inspections.

### Why test and inspection?

Why do we need a test and inspection program? The primary goal is to prevent personnel injury! The test and inspection program is designed to identify sub-standard, defective, damaged, or worn equipment, and remove unsafe equipment from service.

Unsatisfactory equipment and gear shall be removed from service and disposed of or repaired. Equipment shall be stored before and after use in such a way and location so as to prevent damage and not be a hazard to employees. Occasionally, equipment and gear are unsatisfactory as a result of a crane or rigging accident. The activity shall determine if damage was due to a crane or rigging accident, and if so, ensure that the accident is investigated and reported in accordance with NAVFAC P-307 section 12.

**Why Test and Inspection?**

Program goals:

- Prevent personnel injury
- Identify sub-standard equipment
- Remove unsafe equipment

If damaged equipment is discovered, the activity shall determine if damage was due to a crane or rigging accident and, if so, ensure that the accident is investigated and reported in accordance with NAVFAC P-307 section 12.

---

---

---

### Covered Equipment

NAVFAC P-307 Section 14 applies to the following equipment used in weight handling operations: rigging gear (slings, including chain, wire rope, metal mesh, synthetic rope, synthetic webbing, and synthetic roundslings; shackles; eye bolts; swivel hoist rings; links and rings; turnbuckles; insulated links; hooks; etc.), portable LIDs (dynamometers, load cells, crane scales, etc.), crane structures, and portable manual and powered hoists/winches.

---

---

---

### Additional Covered Equipment

Also covered are below-the-hook lifting devices identified in ASME B30.20 (for example spreader beams, container spreaders, plate clamps, magnets, vacuum lifters), personnel platforms, portable gantry/A-frames, and portable floor cranes used for general lifting, and cranes and hoists procured with, integral to, and used solely in support of larger machine systems (milling machines, press brakes, etc.).

---

---

---

#### Covered Equipment

- Rigging Hardware
- Slings
- Portable Load Indicators
- Portable manual and powered hoists/winches
- Crane Structures



#### Additional Covered Equipment

- Below-the-hook lifting devices identified in ASME B30.20
  - spreader beams
  - plate clamps
  - magnets
  - vacuum lifters
  - container spreaders
- Personnel Platforms
- Portable Gantries/A-frames and portable floor cranes



### Equipment Not Covered

Equipment not covered includes ordnance equipment, which falls under NAVSEA OP-5, original equipment manufacturer or OEM installed welded lift lugs, threaded holes and bolt-on pads, OEM provided rigging gear used for limited lifts such as off-loading, reloading, initial storage, and shipment, and equipment in an approved test and inspection program (NAVAIR, NAVSEA, Strategic Systems Program, Army, or Air Force approved program). Where OEM provided specialized rigging equipment is used, the activity shall ensure that the equipment is in good condition and that personnel using the equipment know how it is to be used.

---

---

---

**Equipment Not Covered**

- Ordnance Equipment - NAVSEA OP-5
- OEM Integral Attachment Points
- OEM provided rigging gear for limited lifts:
  - offload
  - shipment
  - storage of OEM product
- Equipment in an approved test and inspection program (NAVAIR, NAVSEA, SSPO, Army, Air Force)

### Equipment Markings

Markings on each piece of equipment are the most apparent way for you, the user, to know the requirements of NAVFAC P-307 have been met. Equipment must be marked per the applicable ASME B30 volume (B30.9 for slings, B30.10 for hooks, B30.16 for portable hoists, B30.20 for below-the-hook lifting devices, B30.21 for lever hoists, and B30.26 for rigging hardware).

In addition to the identification and marking requirements of the applicable ASME volume, except as noted in NAVFAC P-307 Paragraphs 14.8 and 14.11, each piece of equipment must be clearly marked, tagged, or engraved with an indication of the reinspection due date and a unique serial number that will allow it to be traced to its test and inspection documentation.

Below the hook lifting devices weighing more than 100 pounds shall be marked with the weight of the device. Markings must be done in a manner that will not affect the strength of the component. Vibra-etch methods and low stress dot faced stamps are acceptable methods for marking equipment.

**Equipment Markings**

- Gear shall be marked per applicable ASME B30 requirements
- At a minimum, the rated load and manufacturer's name or trademark must be shown

**Special Markings**

- Must provide indication of inspection (either re-inspection due date, color code, or other indicator to identify when re-inspection is due)
- Must not affect strength
- Special markings are not required for rigging hardware or portable load-indicating devices.

Shown on the right is a wire rope sling with a metal band attached to indicate the re-inspection due date.



Contact the OEM for guidance on where and how to mark equipment.

Load tests, documented inspections, and special equipment markings (other than the manufacturer's markings required by B30.26) are not required for equipment covered by ASME B30.26 (shackles, adjustable hardware, compression hardware, links, rings, swivels, rigging blocks, and portable load indicating devices.)

### Multiple Part Equipment

For multiple part equipment that can be separated (for example load indicators with custom shackles), the subordinate part (the shackle) shall be identified to the primary part (load indicator). This is not intended for standard shackles or turnbuckles, equipment that is not field disassembled such as swivel hoist rings, or for equipment for which the activity engineering organization is allowed to designate fasteners by grade only, such as portable padeye/lifting lug fasteners and eyebolt nuts. If space limitations do not permit legible marking, a tag containing required markings shall be attached and engineering guidance shall be obtained.

---

---

---

### Markings on Multi-leg Sling Assemblies

Multi-leg slings assemblies shall be marked with the rated load of each leg, the rated load of the entire assembly, and the sling angle upon which the rated load is based.

---

---

---

---

---

---

---

---

#### Multiple Part Equipment

- For multiple part equipment that can be separated (e.g., load indicators with custom shackles), the subordinate part (the shackle) shall be identified to the primary part (load indicator).
- This is not intended for standard shackles or turnbuckles, or equipment that is not field disassembled such as swivel hoist rings.
- If space limitations do not permit legible marking, a tag containing required markings shall be attached.

#### Multi-Leg Sling Markings

- Rated load of each leg
- Rated load of entire assembly
- Sling angle upon which rated load is based



### Braided Wire Rope Slings

NAVFAC P-307 requires that braided slings shall have the OEM's marking remarked at 70% of the OEM's rated load unless destructive tests are conducted on sample slings. The documentation is reviewed by the Navy Crane Center.

So, there are many additional markings that may be required for different equipment. Not only do these markings have to be present, but they must also be legible.

---

---

---

#### Braided Wire Rope Slings

- Must be re-marked at 70% of OEM Rated Load
- Higher capacities may be approved after:
  - Documented destructive tests
  - Documentation reviewed by Navy Crane Center

### Wire Rope Endless Slings

Endless slings shall have a marked rated load based on a D/d efficiency of 50 percent and may be used over various size pins at loads not exceeding the marked rated load.

Where endless wire rope slings are designed for a particular use, they shall be marked to indicate the pin diameter used to determine the rated load.

---

---

---

#### Wire Rope Endless Slings



- Endless slings shall have a marked rated load based on a D/d efficiency of 50 percent and may be used over various size pins at loads not exceeding the marked rated load.
- Where endless wire rope slings are designed for a particular use, they shall be marked to indicate the pin diameter used to determine the rated load.

### Chain Slings

In accordance with 29 CFR 1915.112 and 29 CFR 1917.42, chain slings used in ship repair, shipbreaking, or cargo transfer require quarterly periodic inspections and must be marked to indicate the date of the next required inspection.

---

---

---

#### Chain Slings - Markings

- When used in cargo-handling, shipbreaking, or ship repair, chain slings require quarterly periodic inspections.
- The sling shall be marked to indicate this inspection frequency.



### Lashing

Lashing must be marked to identify it to the spool or reel from which it came. The rated load must be marked on each piece as well as the reinspection due date.

---

---

---

### Illegible or Missing Markings

Sometimes markings become hard to read due to wear or they may even be removed during a repair process. Replace markings that are hard to read or have been removed. Remember, all rigging equipment must be marked.

---

---

---

### Required Records

Equipment markings should link the piece of equipment to its test and inspection records. NAVFAC P-307 requires documentation of tests and inspections. Records are the auditable proof that equipment has been tested and inspected and provide a basis for ongoing evaluation of the equipment. The latest test and inspection record will be retained on file at the activity. Computer generated files are acceptable if they identify the individual components and inspection results.

---

---

---

#### Lashing - Markings

- Spool or reel
- Rated load
- Re-inspection due date



#### Illegible or Missing Markings

- Replace markings that are hard to read or that have been removed due to wear or a repair process



#### Required Records

- Equipment markings link the piece of equipment to its test and inspection records.
- Records are the auditable proof that equipment has been tested and inspected and provide a basis for ongoing evaluation of the equipment.
- The latest test and inspection record should be retained on file.

### Record Information

NAVFAC P-307 requires that the records include identification of individual components, latest test and inspection results, and dates of inspections and tests. There are many ways to identify the equipment to the records.

---



---



---

### Identifying Gear to its Record

A unique identification number may be used to identify the equipment to its record. The ID number can be as simple or complex as you need it to be. A simple method might be to use a letter designator that represents a particular type of gear followed by a serialized number. Mark the equipment ID number on the gear. Write the ID number on the record. Now the gear has identifiable records.

---



---



---

#### Record Information

MASTER HISTORY RECORD CARD		EQUIPMENT TYPE / DING NO		EQUIPMENT ID	
				CF 127D	
SPD CAPACITY	MANUF. RECOMMENDED PERIODIC TEST VALUE	MAX. MATERIAL REMOVAL AUTHORIZED	PROOF TEST VALUE		
RECORD OF INSPECTION / TESTING CYCLE			MAINTENANCE REPAIR AND MODIFICATION RECORD		
PURPOSE / DESCRIPTION	S	U	DATE	DESCRIPTION	DATE
Annual Load Test Checkout	X		J.W. Inspector 1/27/2008		

#### Information must include:

- ID of individual components
- Test dates
- Latest results

#### Matching Gear to Record



- A unique identification number may be used to identify the equipment to its record.
- A simple method is to use a letter designator that represents a particular type of gear followed by a serialized number.

The picture shows an identification number of "P-341-1.6T" etched or engraved on the swage fitting.

The "P" stands for "Pendant", the number "341" is to identify the pendant to its specific record, and the 1.6T is the capacity or Working Load Limit (WLL).



## Knowledge Check

1. **Select all that apply.** The reason test and inspection is required is to—
  - A. identify sub-standard equipment
  - B. prevent personnel injury
  - C. remove unsafe equipment
  
2. **Select the best answer.** Rigging gear identification markings applied by the activity indicate that the equipment is—
  - A. authorized for use
  - B. in an inspection program
  - C. new to the activity
  - D. not damaged
  
3. **Select the best answer.** Equipment test and inspection requirements in Section 14 of NAVFAV P-307 do not apply to—
  - A. container spreaders
  - B. OEM installed bolt-on pads
  - C. personnel platforms
  
4. **Select all that apply.** Which of the following markings are required on lashing?
  - A. rated load
  - B. reinspection due date
  - C. serial number
  - D. size
  
5. **Select the best answer.** Rigging gear test and inspection records must include—
  - A. identification of individual components
  - B. dates of tests and inspections
  - C. latest test and inspection results
  - D. all of the above
  
6. **Select the best answer.** Matching ID markings on rigging gear are required for—
  - A. all rigging equipment
  - B. chain slings with permanent attachments
  - C. components that can be separated
  - D. end fittings on slings
  - E. rope or chain sling bridle assemblies

7. **Select the best answer.** Rigging gear test and inspection records are required to be kept on file—
- A. for 6 months
  - B. for 1 year
  - C. for 3 years
  - D. until replaced by a more current record

Completion

---

---

---

**Completion**

**Congratulations.**

**You have completed the Rigging Gear Test, Inspection, and Marking Requirements module.**

Click on the Exit button to return to the main module menu.



### Rigging Manuals

Information on rigging techniques can be found in rigging handbooks, rigging manuals, OEM publications, textbooks, and consensus standards.

Let's cover some of the safety precautions that apply to all types of rigging equipment or operations.

---

---

---



### General Safety Rules

Remain alert when performing rigging operations. Hazards are always present. Two common danger areas are between the rigging gear and the load and between the load and other objects. These areas are sometimes referred to as “the bight.” Be sure to keep your hands, feet, and head out of the bight.

---

---

---

#### General Safety Rules

- Remain alert
  - Hazards
  - Danger areas
- Always stay “out of the bight” or “pinch point”
- Do not place any part of your body between the load, rigging gear, or a solid object.

### Homemade Gear

Never use shop made equipment unless it has been approved by engineering and certified for use in weight handling operations.

---

---

---

#### Shop-made Gear



- Never use shop-made gear unless approved and certified.

### Selecting Rigging Equipment

Use rigging gear only for the purpose it is designed for. Rigging gear is a tool like a hammer or wrench. We've all heard the phrase, "Use the right tool for the job." It's the same for rigging gear. If you don't have the right rigging gear to safely do the job, stop and get it. Never use damaged gear. Never use gear past its inspection due date. Your safety and the safety of the rest of the crane team depend on the gear you use and how you use it. Take the time to do it right.

---

---

---

### Selecting Rigging Equipment

Keep the following in mind when selecting rigging equipment. Rigging equipment must be selected based on the total force that will be applied to the gear, not just the weight of the load. Remember, in some cases, the force in one leg of a multiple sling leg could exceed the weight of the load.

Keep the overhead height restrictions or clearances in mind when selecting sling length. Sling lengths that are too long may cause the hook to reach the limit switch before the load reaches the desired height.

You must also think about the hazards the gear may be subjected to so you can choose the appropriate equipment.

#### Selecting Rigging Equipment



- Never use damaged gear.
- Never use gear past its inspection due date.

#### Selecting Rigging Equipment (Continued)

- Base rigging gear on total stress, not just item weight
- Consider height restrictions when selecting sling lengths
- What hazards will it be subjected to?

---

---

---

### Hazards to Rigging Gear

The first major hazard we must talk about is abuse. Here the biggest hazard is you, the user. Don't drag your slings on the ground. Cement or paved surfaces will quickly abrade slings and gear. Contact with the ground can embed grit and abrasives into the sling, which will cause damage. Don't pull slings from under a load while the load is resting on them. Set the load down on blocking to keep from crushing the sling.

---

---

---

#### Hazards to Rigging Gear

- Dragging slings
  - Causes abrasion
  - Embeds grit
- Rest loads on blocks
- Don't rest loads on gear



### Hazards to Rigging Gear: Corrosives & Heat

Keep gear away from corrosives, acids, paint thinners, and any other harmful chemicals. Chemicals that may have a corrosive effect on one type of gear may not affect another. For example, acids would quickly destroy a nylon sling but might not harm another synthetic material.

Protect your gear from all heat sources such as welding, burning, grinding, or heat-treating.

---

---

---

#### Hazards to Rigging Gear

**Corrosives**

- acids
- chemicals
- solvents

**Heat**

- welding
- burning
- heat treatment
- grinding



### Hazards to Rigging Gear: Sharp Edges

Another common hazard is sharp edges. No matter what type of gear you use, sharp edges will leave their mark if the gear is not protected. Never use slings against sharp edges without adequate protection.

---

---

---

#### Hazards - Sharp Edges

Sharp edges can damage equipment!

More Rigging Gear!



### Hazards to Rigging Gear: Electrical

You must be aware of the danger electricity presents when working around energized components or electrical lines. Watch out for welding leads, light strings, shore power, and other common hazards when looking for lay down areas. Wire rope, chain, and metal mesh slings should never be used if they could increase the possibility of electrical shock.

Protect yourself and the gear by ensuring all power is secured prior to installing your gear on or around electrical components.

---

---

---

### Protective Materials

Slings can be easily cut at sharp corners or edges or otherwise damaged by abrasion or excessive bearing stress. Cutting of synthetic slings is the most common type of sling failure, leading to dropped loads. Sling protection material shall be of sufficient thickness and strength to prevent sling damage.

When wrapped around corners and sharp edges, synthetic slings shall be completely blocked from contacting the edge with hard material such as split piping, blocks, or special rounded shoes not soft material such as canvas, fire hose, or leather gloves.

Sling manufacturers also provide products that protect slings from sharp corners or edges. Activities should contact the manufacturer for availability of such products.

---

---

---

#### Hazards - Electrical

Watch out for:

- Welding leads
- light strings
- shore power lines
- Ensure power is secured before hooking on to components.



#### Protective Materials

- Slings can be easily cut at sharp corners or edges or otherwise damaged by abrasion or excessive bearing stress.
- Sling protection shall be used where there is a possibility of the sling being cut or damaged.
- When wrapped around corners and sharp edges, synthetic slings shall be completely blocked from contacting the edge with hard material, such as split piping, blocks, or special rounded shoes.

### Sling Protection

Ensure the rigging configuration is stable, and slings cannot slide off the sling protection. The level of protection required is based on potential damage at the contact interface. Damage potential levels are classified as abrasion, bearing, and cutting. The level of protection chosen shall be commensurate with the type of damage potential.

The person responsible for rigging the load shall be trained in recognizing the different damage types and determining what protection methods, material, and components are required to adequately protect the slings.

---

---

---

**Sling Protection**

- Ensure the rigging configuration is stable, and slings cannot slide off the sling protection.
- The level of protection required is based on potential damage at the contact interface.
- The person responsible for rigging the load shall be trained in recognizing the different damage types and determining what protection methods, material, and components are required to adequately protect the slings.

### Hoist and Crane References

Portable manual and powered hoists/winches shall meet the criteria of ASME B30.16 and OEM recommendations. Portable floor cranes/shop cranes (including attachments used solely on portable floor cranes/shop cranes) shall meet the criteria of ASME P.A.S.E and Original Equipment Manufacturer recommendations. Lever hoists shall meet the criteria of ASME B30.21 and Original Equipment Manufacturer recommendations. Other equipment shall meet the criteria of applicable ASME B30 (e.g., trolleys maintained and inspected in accordance with ASME B30.17) and/or Original Equipment Manufacturer recommendations.

---

---

---

**Hoist and Crane References**



- Portable manual and powered hoists or winches shall meet the criteria of ASME B30.16 and OEM recommendations.
- Portable floor cranes or shop cranes including attachments shall meet the criteria of ASME PASE and OEM recommendations.
- Lever hoists shall meet the criteria of ASME B30.21 and OEM recommendations.
- Other equipment shall meet the criteria of applicable ASME B30 and/or OEM recommendations.



### Using Hoists and Cranes

When using chain hoists and portable floor cranes, ensure hoist capacities meet or exceed the expected load. Load indicating devices may be used in conjunction with hoists to help prevent overload of the hoist and related gear when leveling, rotating, or tilting objects.

---

---

---

### Using Hoist and Cranes

Do not move the load (travel, hoist with a crane, etc.) when it is suspended from a manual chain hoist unless the hand chain is tied off or otherwise secured. This prevents inadvertent operation. A bag can be attached to the hoist body to hold excess chain.

Never use more than one person to pull the hand chain of a manual chain hoist. Do not use excessive force to operate a hoist. Never use extension bars on lever-operated hoists.

---

---

---

### Using Hoist and Cranes

Never use the load chain to choke around an object and never “tip load” the hook.

---

---

---

**Hoists and Crane Usage**



- Ensure hoist and crane capacities meet or exceed the expected load
- Load-indicating devices may be used in conjunction with hoists to help prevent overload of the hoist and related gear when leveling, rotating, or tilting objects.

**Using Hoists and Cranes**



- Do not move the load when it is suspended from a manual chain hoist unless the hand chain is tied off.
  - Prevents inadvertent operation
  - Can help prevent hang ups
- Only one person may operate a chainfall at a time

**Using Hoists and Cranes**



Never choke with load chain

Never "tip load" the hook

### Additional Chain Hoist Requirements

Do not run the load chain all the way out (to the bitter end) on a chain hoist as this puts extra pressure on the holding pin and doesn't allow for any payout adjustment once it is hooked into the load. When using chainfalls, ensure the chain is not twisted due to the lower block being "capsized," or twisted.

---

---

---

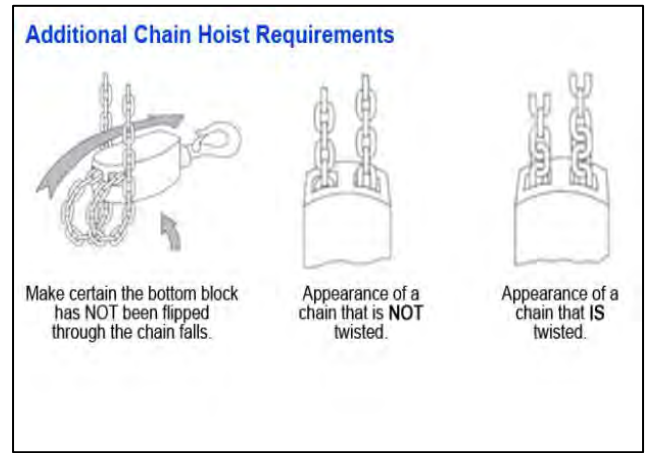

### Additional Rigging Practices

Loads shall be rigged so that the load cannot fall out of the rigging. Frapping shall be used where necessary to ensure the load does not fall out of the rigging. When using slings in a sweeping or basket configuration under a load, the load should be balanced, and the slings should be secured with frapping to prevent inadvertent shifting or movement of the load.

Ends of unused slings/sling legs shall be secured against inadvertent contact when lifting a load. Items susceptible to falling or dislodgement from the lifted load shall be secured or removed prior to the lift.

Pallets shall be of such material and construction and so maintained as to safely support and carry the loads being handled on them. When handling taglines, always face the load, keep hands and feet clear, and do not wrap the tagline around the hands, arms, or any other part of the body. In a choker hitch, a shackle is recommended to be used in the choke point with the shackle pin located in the eye of the sling.

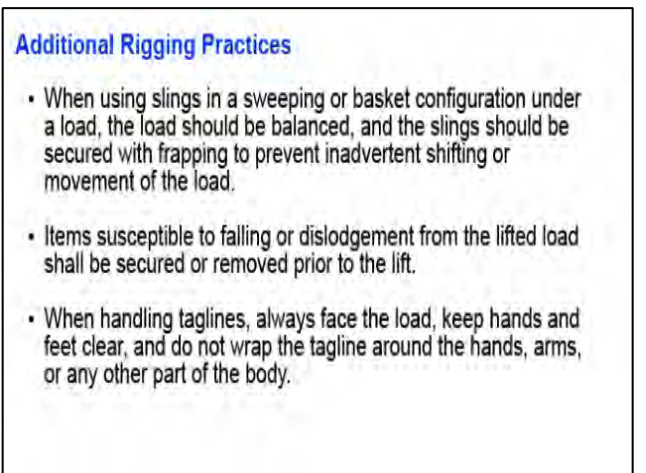

---

---

---

---

---

## Below-the-Hook Lifting Devices

Below the hook lifting devices and container spreaders must be operated in accordance with ASME B30.20 and OEM recommendations. Never use below the hook lifting devices if you do not thoroughly understand the operating characteristics and limitations. Ensure the lifting device has sufficient capacity for the expected load.

---

---

### Below the Hook Lifting Devices

- Follow ASME B30.20 and OEM recommendations
- Be sure you understand operating characteristics and limitations
- Ensure correct capacity for expected load



## Knowledge Check

- 1. Select the best answer.** Which section of NAVFAC P-307 is the rigging gear section?
  - A. Section 8
  - B. Section 10
  - C. Section 12
  - D. Section 14
- 2. Select the best answer. True or False:** It is okay to use homemade rigging gear as long as you are lifting light loads.
  - A. True
  - B. False
- 3. Select the best answer.** When selecting rigging gear for a job, which of the statements below should be followed?
  - A. Base rigging gear on the total stress, not just the weight of the load.
  - B. Consider height restrictions when selecting sling lengths.
  - C. Never use damaged gear.
  - D. Never use gear past its inspection due date.
  - E. All of the above
- 4. Select the best answer.** What should be used between the rigging gear and the load to prevent damage to the load and rigging?
  - A. appropriate sling protection
  - B. metal spacers
  - C. your hand
- 5. Select the best answer. True or False:** Two people can operate a chain fall if the pull chain is too hard for one person to pull while hoisting a load.
  - A. True
  - B. False

## SLING USE

### Welcome

Welcome to the Sling Use module.

---

---

---

### Learning Objectives

Upon successful completion of this module, you will be able to list sling limitations, explain proper sling attachment, and identify the three different hitches and the rated capacities for each.



---

---

---

### Wire Rope Slings

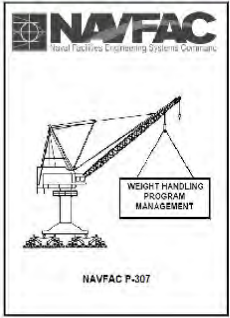
A common metal sling is the wire rope sling. Wire rope slings have some limitations even though they are generally strong and durable. D-to-d is the term for the ratio between the diameter of the object around which the sling is bent and the diameter of the sling body. The capital 'D' represents the diameter of the object, and the small 'd' represents the diameter of the sling. When using wire rope slings, always maintain a minimum D-to-d ratio of one to one in the body of the sling. In other words, never bend a wire rope around a diameter smaller than itself. Bending a wire rope around a diameter smaller than its minimum D-to-d ratio will damage the wires and weaken the sling.



**Welcome**

Welcome to the Sling Use module.

Begin

### Learning Objectives

Upon successful completion of this module, you will be able to:

- List sling limitations
- Explain proper sling attachment
- Identify the three different hitches and the rated capacities for each

### Wire Rope Slings

- Minimum D/d Ratio is 1:1
- Never bend a wire rope around a diameter smaller than its own.

---

---

---

---

### Wire Rope Sling Use

For loads with a non-circular cross section, the bend diameter is derived from the minimum bend diameter of the wire rope around the corner of the load. For slings bent around corners, the corners must be rounded to provide the minimum D/d efficiency. Chafing protection is used to protect the load and sling from damage.

Except for braided slings, wire rope slings shall not be used in single leg vertical hitches unless a method is used to prevent unlaying of the rope.

---

---

---

### Wire Rope Temperature Restrictions

Wire rope must also be protected from extreme temperatures which can seriously affect the wire's strength. Do not use wire rope slings below minus 40 degrees or above 400° Fahrenheit. Fiber core rope wire should not be used above 180° Fahrenheit.

---

---

---

### Wire Rope Sling Restrictions

Wire rope clips should not be used to fabricate slings, and wire rope slings should never be knotted.

---

---

---

#### Wire Rope (Continued)



- Use chafing protection
- Round corners with pipe sections to provide a minimum D/d efficiency of 50 percent
- Do not use at angles less than 30 degrees

#### Wire Rope Temperature Restrictions



Do not use wire rope at temperatures:

- Below -40° F
- Above 400° F (wire core)
- Above 180° F (fiber core)

#### Wire Rope Clips

- Never use wire rope clips to fabricate a sling.



### Chain Sling Use

Chain slings are a good choice when the job demands abrasion and damage resistant slings. However, if used improperly, they too can be damaged.

Chain slings should not be used on loads that are damaged easily. Never use knots or bolts to shorten or extend the sling. Use sling protection materials on sharp corners and edges to prevent damage to slings and the load.

Chain slings shall be used in accordance with ASME B30.9 and OEM recommendations. When a chain sling is used in a choker hitch, the straight-line rated load shall be reduced to reflect the efficiency percentages shown in table 14-3 of NAVFAC P-307. For chain slings with an angle of choke less than 121 degrees, the percent of rated capacity shall be determined by the sling OEM or the activity engineering organization.

### Chain Sling Temperature Restrictions

The sling manufacturer should be consulted when the slings are to be used in temperatures of minus or negative 40 degrees Fahrenheit (F). For slings exposed to temperatures of 400 degrees Fahrenheit or above, follow ASME B30.9 requirements for rated load reduction.

---

---

---

**Chain Sling Use**



- Do not use on items that damage easily
- Do not use knots or bolts to shorten the sling
- Use sling protection materials on sharp corners or edges to prevent damaging slings and the load
- Chain slings shall be used in accordance with ASME B30.9 and OEM recommendations

---

---

---

---

**Chain Sling Temperature Restrictions**



- Consult the sling manufacturer when the slings are to be used in temperatures of minus or negative 40 degrees Fahrenheit (F).
- For slings exposed to temperatures of 400 degrees Fahrenheit or above, follow ASME B30.9 requirements for rated load reduction.

### Metal Mesh Temperature Restrictions

Metal mesh slings are often used in abrasive or high temperature environments that would damage slings. Do not use bare metal mesh slings when temperatures are below -20° or above 550° Fahrenheit. Do not use elastomer coated slings when temperatures are below 0° or above 200° Fahrenheit. Metal mesh slings shall be used in accordance with ASME B30.9 and OEM recommendations.

---

---

---

### Types of Synthetic Slings

There are three types of synthetic slings: synthetic rope slings, synthetic webbing slings, and synthetic roundslings.

Synthetic slings should be used **only** when they can be protected from damage. Natural fiber rope slings are **not to be used** for overhead lifting.

---

---

---

### Using Synthetic Slings

Avoid chemical exposure to synthetic slings and always use sling protection material. Synthetic slings can be easily cut at sharp corners or edges or otherwise damaged by abrasion or excessive bearing stress.

Sling protection shall be used where there is a possibility of the sling being cut or otherwise damaged by abrasion or bearing. Sling protection material shall be of sufficient thickness and strength to prevent sling damage. With high stresses on slings, soft chafing protection material may not maintain the minimum required radius or provide the required protection. In these cases, harder materials, such as split piping sections or special rounded shoes, shall be used.

### Metal Mesh Sling Temperature Restrictions

- Do not use bare metal mesh slings:
  - below -20 degrees F
  - above 550 degrees F
- Do not use elastomer coated slings:
  - below 0 degrees F
  - above 200 degrees F



### Three Types of Synthetic Slings

- Never use synthetic slings when the possibility of damage exists.

Natural fiber rope slings are not to be used for overhead lifting.



### Using Synthetic Slings

- Avoid chemical exposure
- Always use sling protection material
- Minimize exposure to sunlight
  - Store slings indoors
- Use shall be in accordance with ASME B30.9 and OEM recommendations

Ensure the rigging configuration is stable, and slings cannot slide off the sling protection.

The level of protection required is based on potential damage at the contact interface. The level of protection chosen shall be commensurate with the type of damage potential. The person responsible for rigging the load shall be trained in recognizing the different damage types and determining what protection methods, material, and components are required to adequately protect the slings.

Minimize exposure to sunlight and other sources of ultraviolet light. Store all synthetic slings indoors in a cool dry place.

Use of synthetic slings shall be in accordance with ASME B30.9 and OEM recommendations.

### Synthetic Web Sling Use

Synthetic webbing slings shall be used in accordance with ASME B30.9 and Original Equipment Manufacturer recommendations. Where a synthetic webbing sling is used in a choker hitch, the straight-line rated load shall be reduced to reflect the efficiency percentages shown in table 14-3 of NAVFAC P-307.

Web slings must be installed flat around the load without kinks or twists. Kinks and twists reduce friction on the load and can cause the sling to roll or slide out of position. These slings are not affected by D-to-d ratio. Eye length in relation to the diameter of the hook is critical. The eyes of webbing slings are stitched, and the stitching can be damaged if the eye is spread excessively.

---

---

---

---

---

---

---

---

**Synthetic Web Sling Use**

**Install without:**

- kinks
- twists

**Not affected by D/d ratio**



---

---

---



### Using Shackles with Web Slings

Ensure slings are not excessively bunched in the bowl of the hook or in shackles, which can cause uneven loading on the fibers. Shackles used with synthetic web slings must allow the sling to lay relatively flat without excessive curling of the edges. Curling causes uneven loading of the sling. Slight curling, however, is acceptable.

Stacking of synthetic slings is not considered bunching if allowed by the sling Original Equipment Manufacturer, the bearing stress calculations showing allowable stresses are performed and documented by the activity engineering organization, and the resulting bearing stress is within the sling Original Equipment Manufacturer allowable levels.

#### Using Shackles with Web Slings

- Shackles used with synthetic web slings must allow the sling to lay relatively flat without excessive curling of the edges.
- Stacking of synthetic slings is not considered bunching if allowed by the OEM, bearing stress calculations are performed by the activity engineering organization, and bearing stress is within the sling OEM allowable levels.



### Web Sling Temperature Restrictions

Polyester and nylon webbing slings shall not be used in contact with an object or at temperatures in excess of 194 degrees or below negative 40 degrees Fahrenheit.

#### Synthetic Web Sling Temperature Restrictions



- Do not use in contact with an object or at temperatures in excess of 194° Fahrenheit or below -40° Fahrenheit

### Synthetic Rope Use

Synthetic rope slings shall be used in accordance with ASME B30.9 and Original Equipment Manufacturer recommendations. Stranded synthetic rope slings shall not be used in a single part vertical hitch unless a method is used to prevent unlaying of the rope. When making single point lifts with eye and eye synthetic rope slings, use two slings or double up a single sling. If they are allowed to spin, the splice could come undone and drop the load.

#### Synthetic Rope Sling Use

- Use shall be in accordance with ASME B30.9 and OEM recommendations
- Stranded slings shall not be used in a single part vertical hitch
- The minimum D-to-d ratio is 1 to 1



The minimum D-to-d ratio is 1 to 1. This means a one half-inch diameter synthetic rope sling cannot bend around any object that is smaller than one half-inch.

Synthetic rope slings shall not be substituted for other types of slings shown on rigging sketches without prior engineering approval.

---

---

---

### Synthetic Rope Temperature Restrictions

Polyester and nylon rope slings shall not be used in contact with an object or at temperatures in excess of 194 degrees or below negative 40 degrees Fahrenheit.

---

---

---

### Roundsling Use

Synthetic roundslings shall be used in accordance with ASME B30.9 and Original Equipment Manufacturer recommendations. Roundslings shall be used only in the lifting application for which they were designed by the OEM and in strict compliance with the OEM's instructions. For new roundslings, a certificate of proof test shall be retained in the history file for the life of the sling. Where a synthetic roundsling is used in a choker hitch, the straight-line rated load shall be reduced to reflect the efficiency percentages shown in NAVFAC P-307 table 14-3. They shall not be used in a choker hitch if the sling OEM recommends against this practice.

---

---

---

#### Synthetic Rope Sling Temperature Restrictions



- Polyester and nylon rope slings shall not be used:
  - in contact with an object
  - at temperatures in excess of 194 degrees
  - at temperatures below negative 40 degrees Fahrenheit.

#### Roundsling Use



- Use shall be in accordance with ASME B30.9 and OEM recommendations
- When used in a choker hitch, the straight-line rated load shall be reduced to reflect the efficiency percentages shown in NAVFAC P-307 table 14-3

### Other Roundslings

Roundslings constructed of yarns other than nylon or polyester, (e.g., Kevlar, Spectra, Dyneema, Vectran, Technora) (referred to here as “high performance fiber roundslings”) shall be used in accordance with WSTDA-RS-1-HP in addition to ASME B30.9, Original Equipment Manufacturer recommendations, and the additional requirements of NAVFAC P-307.

---

---

---

### Round Sling Temperature Restrictions

Polyester roundslings shall not be used in contact with objects or at temperatures above 194 degrees or below negative 40 degrees Fahrenheit.

---

---

---

### Common Sling Use Rules

Slings must not be used at angles less than 30° from horizontal unless specifically authorized by an engineering work document. Never use a sling that has been knotted. Use sling protection as needed. Rigging gear including slings, shackles, turnbuckles, and eyebolts must be sized such that two legs can carry the load to allow for variations in sling length and load flex.

---

---

---

#### Other Roundslings

- Roundslings constructed of yarns other than nylon or polyester shall be used in accordance with WSTDA-RS-1-HP in addition to ASME B30.9, OEM recommendations, and the additional requirements of NAVFAC P-307.



#### Roundsling Temperature Restrictions



- Polyester roundslings shall not be used:
  - in contact with objects
  - at temperatures above 194 degrees Fahrenheit
  - at temperatures below negative 40 degrees Fahrenheit

#### Sling Use Considerations

- Don't use slings at angles less than 30 degrees from horizontal
- Use sling protection as needed
- Rigging gear must be sized so that two legs carry the load weight



### Eye Length vs. Hook Diameter

The size of the hook or shackle relative to the size of the sling eye can be critical. If we place a ten-inch-long sling eye on a load which is 3 inches in diameter, the eye opens slightly and causes very little added stress to the eye or the splice. However, if we place that sling on a hook with a diameter of 8 inches, this can stress the eye and can cause the swage or stitches to fail.

Never place the eye of a wire rope sling around an object which has a diameter greater than 1/2 the length of the eye. Never place the eye of a synthetic web or rope sling around an object which has a diameter greater than 1/3 the length of the eye. If the hook diameter is too large, a shackle can be used to connect the slings to the hook thereby reducing the diameter over which the sling eyes are placed.

**Eye Length vs. Hook Diameter**

**For Wire Rope Slings:**  
Never: place an eye around a diameter greater than 1/2 the eye length.

**For synthetic web and rope slings:**  
The object cannot be greater than 1/3 the length of the eye.

---

---

---

### Attaching to Hook

When attaching rigging gear to hooks, be sure the safety latch is working properly and closes the throat opening without obstruction. Failure to do so can allow the gear to come off the hook. All gear attached to the hook must seat properly in the bowl. Do not stack slings or allow slings to cross each other in the hook. That can lead to crushing of the slings.

**Attaching to Hook**

- Safety latch works properly
- Gear seats properly in the bowl of the hook

---

---

---

### Correct use of Slings on Hooks

These graphics illustrate correct ways to attach slings to a hook. Graphic “A” shows a vertical application with two sling eyes seated in the bowl of the hook. Graphic “B” shows two slings doubled over the hook and sling eyes pointing down to attachment points. Graphic “C” shows two slings doubled with sling eyes on the hook and the bight pointing down to attachment points. When wire rope slings are used as in graphics “B” and “C” and a heavy load is applied, individual wires may become permanently deformed or bent. If a sling is doubled to the point where it is permanently set, it should not be used in a vertical or straightened out configuration because straightening the sling could cause the wires to break in the strands.

---

---

---

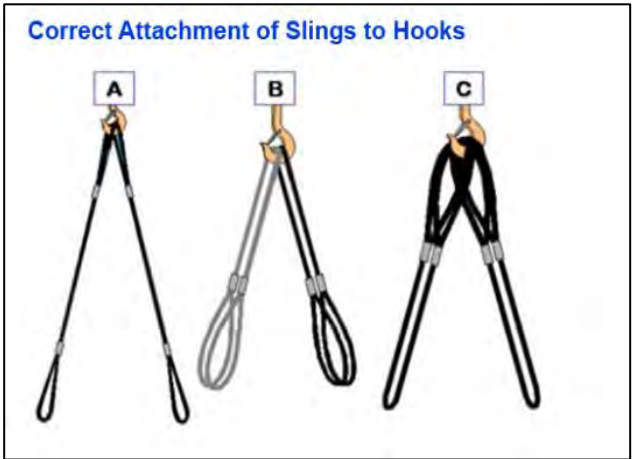

### Incorrect use of Sling on Hooks

These graphics illustrate some incorrect ways of attaching slings to a hook. Incorrect sling applications can be extremely dangerous and can result in loss of load control and personnel injury! Graphic “A” shows a single sling with the “bight” riding the hook and the eyes attached to two separate attachment points. Slings applied in this manner could slip on the hook causing the load to shift. Graphic “B” shows a sling through two attachment points. Installing a sling through more than one attachment point will create excess stress on the sling, the attachment points, and the gear.

---

---

---

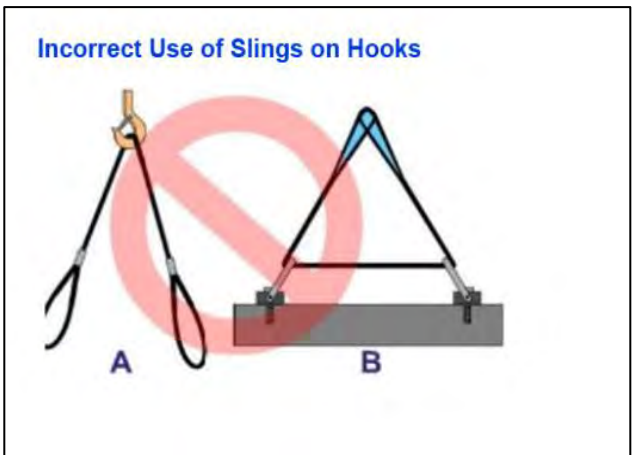

### Included Angle

Included angle is the angle measured between two slings sharing a common attachment point. Where slings are supported in a hook, the included angle of the slings shall not exceed 90 degrees unless otherwise approved by the activity engineering organization. Hooks shall not be loaded at the point or tip or be side loaded.

---

---

---

**Included Angle**

- Where slings are supported in a hook, the included angle of the slings shall not exceed 90 degrees.
- Hooks shall not be loaded at the point or tip or be side-loaded.



### Inside and Outside Slings

When rigging four slings to a hook, separate the slings into two pairs, inside and outside, so they do not pull in the plane of the hook. Attach the inside slings to one end of the object and the outside slings to the other end being careful that they are not crossed.

---

---

---

**Inside and Outside Slings**

- Inside slings to one end of the object
- Outside slings to the other end

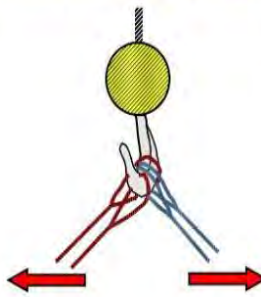

### 3 Types of Hitches

Slings are used in straight-line, choker, and basket hitches. A straight-line hitch is commonly referred to as a vertical hitch. The rated load for the same sling with each hitch will be different.

---

---

---

**Types of Hitches**

- 3 types of hitches:
  - Straight-line
  - Choker
  - Basket
- Rated load depends on the size and type of sling and how it is used

### Rated Loads of Straight-Line Hitches

The rated load for a straight-line hitch is 100% of the sling's capacity. Sling angle stress is encountered any time the straight-line angle exceeds 5° and must be taken into account.

---

---

---

**Rated Loads of Straight-Line Hitches**

- 100% capacity
- Must account for sling angle stress when the angle from the straight line exceeds 5°



The diagram shows a vertical black sling with a hook at the top and a loop at the bottom. A red dashed line extends from the hook downwards, and a red arrow points to the angle between this dashed line and the actual sling, which is labeled as 5°. Another red arrow points to the sling itself.

### Use 2 Legs for Straight-Line Hitches

To prevent unlaying of wire rope (except for braided slings) or stranded synthetic rope slings, the slings shall not be used in a single part straight-line (vertical hitch) or choker hitch unless a method is used to prevent unlaying of the rope. Use two legs for single point lifts. The second leg prevents the sling from spinning.

It is important to note that the configuration shown here does not increase the rated load because slings are rarely the exact same length. The shorter of the two will carry the load.

---

---

---

**Use 2 Legs for Straight-Line Hitches**

- 2 legs prevent unlaying



The image shows two scenarios. On the left, a single-leg hitch is shown with a red 'X' over it and the text 'Sling tries to unlay'. On the right, a two-leg hitch is shown with the text 'Does not increase WLL'.

### Choker Hitches

Using a shackle to set a choker hitch will prolong the life of the sling. Whenever a shackle is used to set a choker hitch set the eye of the sling on the pin of the shackle. This will prevent the "running" part of sling from rotating the pin of the shackle as it passes over it. Never set the choker so the running part of the sling passes against the shackle pin.

---

---

---

**Choker Hitches**

- Set the eye on the pin and the running part against the bow
- Never pass the running part against the pin.



The image shows a choker hitch with a red 'X' over it, indicating it is an unsafe practice.

### Rated Loads of Choker Hitches

Whenever a choker hitch is used, the sling's rated load is reduced. The natural choke angle is 135°, if a choker hitch is allowed to tighten itself as the load is lifted. When choke angles are less than 121°, the rated load must be reduced further.

---



---



---

**Rated Loads of Choker Hitches**

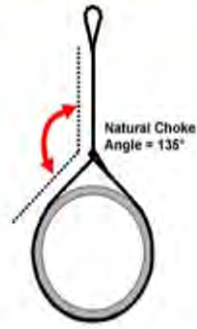

Natural Choke Angle = 135°

- Whenever a choker hitch is used, the sling's rated load is reduced.
- Angles less than 121° reduces the rated load even more.

### Wire and Synthetic Rope Sling Choker Hitch Efficiencies

This chart shows the efficiency of the sling's capacity when choking with a wire rope or synthetic rope sling. Refer to NAVFAC P-307 Table 14-3 for choker efficiencies of other slings. For angles 121° to 135°, the rated load is reduced to 75% of the vertical capacity (Synthetic Web Slings, Roundslings, and Chain Slings are rated at 80%). Check with the OEM or activity engineering organization for ratings of chain slings at angles of choke less than 121 degrees. This does not apply to braided multi-part wire rope slings.

---



---



---

**Efficiency of Slings Used in a Choker Hitch Configuration**

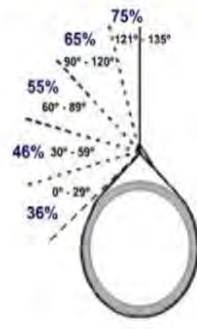

- Wire rope and Synthetic rope slings are rated at 75% of the rated capacity from 121 to 135 degrees.
- Synthetic web slings, roundslings, and chain slings are rated at 80%.
- Check with the OEM or activity engineering organization for ratings of chain slings at angles of choke less than 121 degrees.

### WLL of Basket Hitch

Basket hitches are the strongest of the three hitches. Slings in a basket hitch can carry 200% of the sling's single rated load when the sling angle is less than 5° from vertical, and the required D-to-d ratio is maintained. Wire rope requires a D-to-d ratio of greater than 40 to 1. Synthetic rope requires a D-to-d ratio of at least 8 to 1.

---



---



---

**Basket Hitches**

200% rated load when:

- Vertical angle 5° or less
- No twists in slings
- Maintain D/d ratio:
  - Wire rope = greater than 40
  - Synthetic rope = 8 or greater





### Knowledge Check

- Select the best answer.** The minimum depth of thread engagement for a  $\frac{3}{4}$  inch eyebolt into a steel object is—
  - 1:1
  - 2:1
  - 3:1
  - 4:1
- Select the best answer. True or False:** D/d ratio does not affect synthetic web slings.
  - True
  - False
- Select the best answer. True or False:** It is acceptable to bend a 1-inch wire rope sling around a  $\frac{3}{4}$  shackle.
  - True
  - False
- Select the best answer.** The minimum D/d ratio allowed for wire rope slings is—
  - 1:1
  - 2:1
  - 3:1
  - 4:1
- Select the best answer to fill in the blank.** With the proper D/d ratio, a sling in a basket hitch can lift \_\_\_\_\_ of the rated load of the sling.
  - 75%
  - 100%
  - 150%
  - 200%

### Completion

---

---

---

#### Completion.

Congratulations.

You have completed the Sling Use module.

Click on the Exit button to return to the main module menu.

## SAFE OPERATIONS

### Welcome

Welcome to the Safe Operations module.

---

---

---

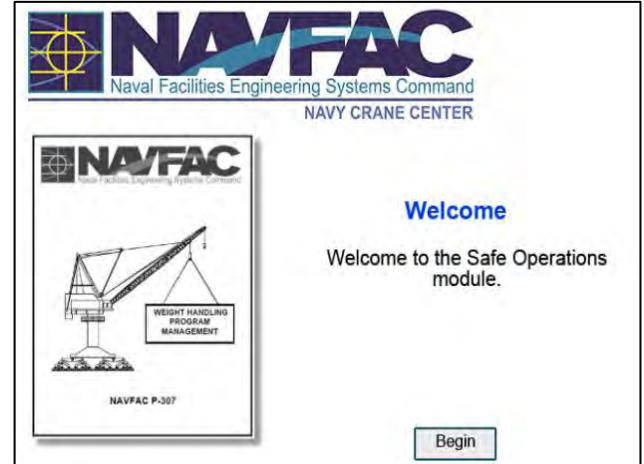

### Learning Objectives

Upon successful completion of this module, you will be able to explain operator responsibilities, describe proper methods to lift and land loads, understand the requirements when working near overhead power lines, identify safe operating procedures, and state securing procedures for cranes.

---

---

### Learning Objectives

Upon successful completion of this module, you will be able to:

- Explain operator responsibilities
- Describe proper methods to lift and land loads
- Understand the requirements when working near overhead power lines
- Identify safe operating procedures
- State procedures for securing cranes

### Understanding the Crane

The vast majority of crane accidents are the result of personnel error and are therefore avoidable. Where team personnel are at fault, it is typically due to inattention, poor judgment, overconfidence, or haste to get the job done. Crane operators at naval activities may be required to operate various types, makes, and models of cranes. Operators must be trained, licensed, and thoroughly familiar with the operating characteristics including posted operational restrictions or limitations of each type, make, and model of crane that may be operated.

**Note:** A license is not required for operators of category 3 non-cab operated cranes.

### Understanding the Crane

#### Operators must:

- Be trained
- Hold a valid operator's license (if required)
- Be familiar with the crane before operating

**Note:** A license is not required for operators of Category 3 non-cab operated cranes.



---

---

---

### Operator Training

Prior to being licensed, operator trainees must be thoroughly trained on the operation of the type of crane for which a license is to be issued.

The operator trainee shall operate the crane only under the direct observation of a licensed operator. The licensed operator shall retain full responsibility for the safe operation of the crane. The supervisor shall approve lifting of loads based upon the candidate's demonstration of knowledge, skill, and ability with the crane and safe operation without loads. The trainee shall not perform complex lifts.

**Note:** A license is not required for operators of category 3 non-cab operated cranes.

### Operator Training

Prior to being licensed, operator trainees must be thoroughly trained on the operation of the type of crane for which a license is to be issued.

- The trainee shall operate the crane only under the direct observation of a licensed operator
- The licensed operator shall retain full responsibility for the safe operation of the crane
- The supervisor shall approve lifting of loads
- The trainee shall not perform complex lifts

**Note:** A license is not required for operators of Category 3 non-cab operated cranes.

### Operations Manual

Operators must read and follow the manufacturer's requirements, written procedures, safety instructions, and precautions.

---

---

---

### Operations Manual

Operators shall read and follow manufacturer's requirements:

- Operating procedures
- Safety instructions
- Precautions



### Posted Information

The operator must heed posted warnings and instructions on the crane such as hand signal placards, controller function labels, and warning labels. Certification information should be posted in plain sight.

---

---

---

### Posted Information

- Standard hand signal chart
- Controller function labels
- Warning tags and labels
- Certification information
  - Crane ID number
  - Certification expiration date
  - Rated capacity of the crane
  - Rated capacity of each hook



**Note:** Hand signal charts or placards are not normally posted on non-cab operated category 3 cranes.

## Pre-Operational Check

To make sure the crane and work area are safe, a complete check of the crane shall be performed by the operator prior to the first use of the crane each day.

When performing the operational check in cold weather or icy conditions, the operator should raise the blocks and boom before lowering them to avoid damage when sheaves may be frozen.

Operators should inform rigging personnel to stand clear of the area below the blocks and boom prior to operation.

The operator should hoist up slowly, in small increments, to break any ice and/or snow free and monitor the sheaves to ensure proper movement and operation of the sheaves and wire rope. This should also be performed periodically throughout the day to ensure proper operation during cold weather or icy conditions.

### Pre-Operational Check

**The Pre-Operational Check is:**

- Mandatory
- Performed prior to use each day
- Ensures safety by checking all crane functions



When performing the operational check in cold weather or icy conditions, the operator should raise the blocks and boom before lowering them to avoid damage when sheaves may be frozen.

---

---

---

---

---

## Knowledge Check

- 1. Select the best answer.** When operating cranes, the operator's primary responsibility is to—
  - A. do pre-use checks
  - B. keep the crane clean
  - C. operate safely
  - D. use the shortest boom length possible
  
- 2. Select the best answer.** Crane operators at naval activities may operate various types, makes, and models of cranes for which they are licensed. How must safety and operator proficiency be assured under these circumstances?
  - A. Operators must be familiarized (as directed by a supervisor) before operating.
  - B. Operators must operate at reduced speeds until confident and capable.
  - C. Operators must receive written and performance tests by a crane license examiner as outlined in the NAVFAC P-307 manual.
  
- 3. Select the best answer.** What information should be posted, clearly understandable, and readily available to the operator?
  - A. Certification information
  - B. Crane Operator's license number
  - C. Travel speed through congested areas

4. **Select the best answer.** Which of the following operator responsibilities is considered the basis for ensuring a safe and reliable crane?
- A. firm and level supporting surface
  - B. periodic lubrication and servicing
  - C. proper setup on outriggers
  - D. the pre-use check or operator's daily checklist (ODCL)
5. **Select the best answer.** What information should be posted, clearly understandable, and readily available to the operator?
- A. labels for each control function
  - B. ODCL checks
  - C. Operator's license number
6. **Select the best answer.** When can an unlicensed crane operator trainee operate a crane?
- A. in an emergency
  - B. only under the direct observation of a licensed operator
  - C. when he or she needs to operate a crane to get the job done
  - D. when his or her supervisor tells him to operate a crane

### Operator Awareness

When operating a crane, the operator must be aware of everything in the operating envelope including hazards, obstructions, and personnel. At the same time, the operator must be aware of the sound, feel, and behavior of the crane.

---

---

**Operator Awareness**

Operators must be aware of:

- Hazards
- Obstructions
- Personnel in the area
- Other cranes
- Characteristics of the crane



### Unsafe Conditions

Whenever an unsafe condition exists, operators must immediately stop operation, and the condition must be resolved before continuing. If you cannot resolve a safety issue with the team members, contact the supervisor for assistance. Remember, operators have the authority and responsibility to stop and refuse to operate the crane until safety is assured.

---

---

**Upon Encountering Unsafe Conditions**

Operators must:

- Stop all operations
- Resolve unsafe conditions with the team
- Notify supervision when necessary

Operators have the **authority and responsibility** to stop and refuse to operate the crane until safety is assured.

**Lifts Near Personnel**

Loads must never be moved or suspended over personnel. Choose an alternate load path or evacuate personnel from the area.

---



---



---

**Lifting Near Personnel**



**Loads must never be moved or suspended over personnel.**

- Avoid moving loads near personnel work areas
- Look for an alternate route
- Evacuate personnel from the load path area

**Riding Loads**

Personnel must never ride loads. Use only approved personnel-lifting devices if personnel must be lifted.

---



---



---

**Riding Loads**



**Personnel must never ride or climb on suspended loads.**

- Adjust rigging from other access if possible
- Look for an alternate route
- Never use the load as a means of transportation!

**Overhead Lines**

Whenever working near overhead power transmission lines, have the power de-energized and visibly grounded.

When the power cannot be de-energized, the minimum required clearances described in Figure 10-3 of NAVAC P-307 must be maintained. If any part of the crane or load could approach the distances noted in Figure 10-3 of NAVAC P-307, a designated signaler shall be assigned. In addition, a supervisor shall visit the site, assess potential hazards, and establish procedures to safely complete the operation.

Follow the requirements of NAVFAC P-307 Paragraphs 10.11.1 through 10.11.1.6 for crane operations near or below overhead electrical transmission lines, operation near communication towers, and travelling below power lines.

**Overhead Electrical Power Lines**

- Should be de-energized and visibly grounded if possible
- If the lines can't be de-energized:
  - Maintain limit of approach
  - Allow for wind sway
  - Use a designated spotter
- Follow the requirements of NAVFAC P-307 paragraphs 10.13.1 through 10.13.6 for crane operation near or below overhead electrical transmission lines, operation near communication towers, and traveling below power lines.

VOLTAGE, KV (PHASE TO PHASE)	MINIMUM REQUIRED CLEARANCE, FT./M
Operation (near) High Voltage Power Lines	
0 to 50	20 (6.10)
Over 50 to 200	20 (6.10)
Over 200 to 350	20 (6.10)
Over 350 to 500	50 (15.24)
Over 500 to 750	50 (15.24)
Over 750 to 1000	50 (15.24)
In Transit with No Load and Booms or Mast Lowered	
0 to 0.75	4 (1.22)
Over 0.75 to 50	6 (1.83)
Over 50 to 345	10 (3.05)
Over 345 to 750	16 (4.87)
Over 750 to 1000	20 (6.10)

Figure 10-3

---



---



---



---

### Overhead Power Lines: Limit of Approach

When operating a crane in the vicinity of overhead electrical transmission lines, for voltages less than 350 kV, the minimum required clearance is 20 feet. Where the voltage is known to be 350 kV or more, the minimum required clearance is 50 feet.

A designated spotter shall be assigned by the supervisor and be positioned to effectively gauge and monitor the clearance distance and communicate directly with the operator.

When operating in the vicinity of overhead transmission lines, the best crane set up is one in which no part of the crane or load can enter the clearance limit. Even boom failure should not allow the crane, load line, or load to enter the limit.

#### Limit of Approach

- For voltages less than 350 kV, the minimum required clearance is 20 feet.
- For voltages 350 kV or greater, the minimum required clearance is 50 feet.
- Use a designated spotter to ensure the minimum clearance is maintained.



---

---

---

### Operating Practices

The crane operator must operate the crane in a safe manner moving loads slowly and smoothly. Avoid rapid starts and sudden stops to help reduce load swing. Anticipate stopping points and slow down before bringing loads to a stop. Crane swing should be relatively slow to prevent outward swing of the load due to centrifugal force.

The operator shall remain at the controls at all times while a load is suspended from the crane. This does not include slings and other gear used to rig the load and does not include a load attached to the crane with slack in the rigging gear. This also does not apply to under-running bridge cranes, jib cranes, pillar cranes, pillar jib cranes, monorails, and fixed overhead hoists used in industrial processes that require a suspended load such as cleaning, degreasing, painting, testing, and similar processes. For such cases, the suspended load shall be less than 80 percent of the crane's rated capacity, the area shall be secured to prevent unauthorized personnel from entering, the crane shall be tagged to indicate this condition, and the load shall not be suspended longer than required.

#### Operating Practices

Operate the crane smoothly by:

- Avoiding rapid starts
- Avoiding sudden stops
- Anticipating stopping points



Never leave suspended loads unattended.

---

---

---

---

---

---

---

### Crane Operating Characteristics

There are a variety of operating characteristics and issues that the users of Category 2 and 3 cranes must consider. Listed below are just a few.

Operating of Category 2 and 3 cranes may be from the cab or from the ground using a pendant controller or remote controls. A disadvantage of operating a very high mounted overhead traveling crane from the cab is that the operator may have difficulty in judging position and in seeing signals.

Some cranes are equipped with dynamic lowering controls. A dynamic lowering control is an automatic device that speeds the lowering of an empty hook or light load and slows a heavy load.

On some cranes, a heavy load may lower when the hoist control is initially moved from the neutral position to the hoist position. The load may not lift until the hoist speed is high enough to support and raise the load. This characteristic is called hoist roll back. When positioning heavy loads, the final vertical adjustment should be made by lowering the load because of hoist roll back.

#### Operating Characteristics

- Visual and communication concerns
- Dynamic lowering control
- Hoist Roll Back



---

---

---

---

---

---

### Operating OET and Gantry Cranes

Overhead electric traveling cranes are generally operated indoors, so congestion is often an issue.

Watch for changes in the work area that may cause interference. Storage racks with material stacked too high are a common problem.

Operators should always check for trolley and bridge drift before operating the crane.

Lift loads vertically. Side pulls can cause uneven or overlapped spooling of the hoist wire and may cause the wire rope to be cut or severely damaged. In addition, ensure the hook and block are not swinging prior to hoisting. Improper or overlapped spooling of the wire rope on the drum can occur with or without a load on the hook when hoisting.

Avoid sudden starts and stops with the bridge. This can result in skidding and uneven wear on the wheels. A sudden start with a heavy load on one end of the bridge or a slippery track may cause a crane to skew. Skewing is a condition where one end of the bridge

#### Operating OET and Gantry Cranes

- Watch for travel interference
- Check for trolley and bridge drift
- Lift loads vertically
- Avoid sudden starts and stops



**Warning:** Hoisting with the hook or block swinging can result in improper or mis-spooling of the wire rope on the drum with or without a load on the hook.

---

---

---

---

---



gets ahead of the other end, frequently causing binding on the rails. Excessive skew may be straightened by slowly bumping the bridge into the end stops.

### Operating Techniques

When slowly taking the slack out of rigging gear and when starting to move a light load or empty hook smoothly, the first hoisting point or slowest possible speed should be used.

A technique called "Inching," or performing a motion very slowly a little at a time, can be used when a crane operation or function requires small movement.

Another technique, "Plugging," is the use of reverse power instead of a brake to slow or stop the bridge or trolley travel. This method of braking or stopping movement is not used for hoisting or lowering motions. As a precaution, the operator should be ready to use the foot brake to stop movement if the power or operation should fail.

### Lifting Loads

Prior to lifting, position the freely suspended hook directly over the load's center of gravity when attaching the load. This prevents side loading the boom or crane and prevents dragging or shifting of the load as it is picked up.

Sufficient tag lines shall be used to minimize load swing and rotation unless their use creates a hazard.

Take the slack out of rigging gradually and watch for hook movement that indicates the need to reposition the crane before lifting.

When lifting a load, stop hoisting when the load lifts a few inches off the ground and check to ensure there is no slippage of the hoist brake. This must be performed for every load.

Accelerate smoothly to reduce dynamic loading.

Extreme caution shall be used when making lifts out of water. When the load comes out of the water, buoyancy is lost, and the load on the crane may increase. Also, just as the load leaves the water, the surface tension (suction) can increase the load on the crane momentarily. Water held inside the object may also increase the load weight.

#### Operating Techniques

- Operating speed
- Inching
- Plugging



#### Lifting Loads

##### Lifting procedure:

- Attach tag lines for control
- Take up slack gradually
- Lift slowly
- Stop and check the hoist brake
- Accelerate smoothly



### Landing Loads

Prior to lowering loads, be sure the surface that you plan to land the load on will support the load. When landing loads, slowly lower the load as you approach the landing surface, stop the load a few inches off the ground or landing surface, then slowly lower the rest of the way. Ensure the load is stable and secure before slacking and removing the rigging gear.

---

---

---

### Securing the Crane

When securing cranes, remove gear from the hook, stow hooks near but not in the upper limit switches, place all controls in the neutral or off position, engage all brakes, rotate locking devices and drum pawls, and secure power. Operators shall ensure local safety requirements are followed. For mobile cranes, set the carrier brake and chock wheels if the crane is on an incline.

---

---

### Traveling Cranes with Loads

When traveling cranes with loads, stow unused hooks, follow OEM requirements, and keep loads close to the ground while avoiding obstructions. When initiating travel movements and when the load or crane is approaching personnel, the warning horn or signal, if so equipped, shall be sounded. Maintain communication with and operate under the direction of a signaler. Use slow speeds for better load control. Be aware of travel restrictions and other cranes working in the area. Remember to check clearances and watch for obstructions.

---

---

---

#### Landing Loads

- Be sure the surface will support the load:
  - Slowly lower the load
  - Stop a few inches from the landing point
  - Slowly lower the rest of the way
- Ensure the load is stable and secure prior to removing rigging gear.



#### Securing the Crane

##### Securing procedure:

- Remove gear from the hook
- Raise hooks below the limit switch
- Place controls in neutral
- Set all brakes and locks
- Secure power
- Secure the crane



#### Traveling Cranes with Loads

##### When moving cranes with loads:

- Follow OEM requirements
- Keep loads just high enough to clear obstacles
- When initiating travel and when approaching personnel, the warning horn or signal shall be sounded
- Use slow speeds
- Stow unused hooks
- Look for other cranes nearby
- Be aware of any travel restrictions
- Check clearances and obstructions
- Maintain communication and operate under the direction of a signaler



## Summary

In this module, we discussed operator responsibilities including taking the time to get familiar with the crane's operating characteristics, reading and following the operations manual, having the required information on the crane, and performing the ODCL; safe operating practices, operator awareness, and proper methods for lifting and landing loads; the rules and requirements including limits of approach for operating cranes in the vicinity of overhead power lines; and how effective teamwork and safe operating practices reduce accidents.

---

---

---

### Safe Operations Summary

In this module, we discussed the following:

- Operator responsibilities including taking the time to get familiar with the crane's operating characteristics, reading and following the operations manual, having the required information on the crane, and performing the ODCL.
- Operator awareness, safe operating practices, and proper methods to lift and land loads.
- Overhead power line rules and requirements for operation including limits of approach for operation and traversing cranes.
- By practicing safety procedures, accidents can be avoided. Effective teamwork can and will reduce accidents.

## Knowledge Check

7. **Select the best answer.** When lifting loads with a crane, which of the following is the first thing an operator should do?
- A. center the hook over the center of gravity of the load
  - B. change speeds smoothly
  - C. lift the load slightly to check the brake
  - D. take the slack out of the rigging
8. **Select the best answer.** The second step in the procedure for lifting loads is to—
- A. hoist at one speed until the load lifts
  - B. hoist slowly and remove slack from the rigging gear
  - C. hoist slowly until the load lifts
9. **Select the best answer.** The third step for lifting loads is to—
- A. lift the load until a desired height and stop
  - B. lift the load until completely suspended and stop
  - C. lift until the load clears all obstacles and stop

- 10. Select the best answer.** While operating, the crane operator becomes concerned over the safety of the lift. The Rigger-in-Charge sees no problem and tells the operator to continue. The operator should—
- A. note the incident on the back of the ODCL card
  - B. proceed slowly with caution
  - C. refuse to continue until safety is assured
  - D. tell his/her supervisor at the end of the shift
- 11. Select the best answer.** Side loading a crane boom by dragging loads or lifting a load with a nonvertical hoist may result in—
- A. destructive stresses placed on the boom and sheeves
  - B. possible overload due to swinging of the load after lifting
  - C. uncontrolled movement of the load due to shifting
  - D. all of the above
- 12. Select the best answer.** In general, which of the following things should an operator do when traveling cranes with loads?
- A. Avoid sudden stops.
  - B. Keep loads just high enough to clear obstacles.
  - C. Start slowly and gradually increase speeds.
  - D. Stow or secure unused hooks.
  - E. All of the above
- 13. Select the best answer.** If a heavy load shall be inched into an exact vertical position, should the final adjustment be made by raising or lowering? Why?
- A. By hoisting. When hoisting, the load may lower before the speed is high enough to lift the load.
  - B. By hoisting. When lowering, the speed may not be controllable.
  - C. By lowering. When hoisting, the load may inadvertently lower while the controls are moved from neutral to a hoist speed high enough to support and raise the load.

Completion

---

---

---

**Completion**  
Congratulations.  
You have completed the Safe Operations module.  
Click on the Exit button to return to the main module menu.

**SAFE OPERATIONS MODULE 2**

Welcome

Welcome to Safe Operations Module 2.

---

---

---



Learning Objectives

Upon successful completion of this module, you will be able to explain specific crane operating principles and securing procedures for mobile hydraulic cranes, mobile lattice boom cranes, floating cranes, portal cranes, locomotive cranes, and Overhead Electric Traveling (OET) and gantry cranes.

---

---

---

Learning Objectives

Upon successful completion of this module, you will be able to explain specific crane operating principles for:

- Mobile Hydraulic Cranes
- Mobile Lattice Boom Cranes
- Floating Cranes
- Portal Cranes
- Locomotive Cranes
- OET and Gantry Cranes

Mobile Crane Operating Terms

There are five common modes of operation for a typical mobile crane: booming up or down, rotating, traveling, hoisting up or down, and extending and retracting the boom. Raising or lowering the boom is also known as booming or luffing.

Rotate, sometimes called swing or slew, causes the upper-works of the crane to revolve on the carrier.

Travel mode allows the operator to move the entire crane on wheels, tires, or crawler tracks. Hoist mode is used to raise and lower the hooks.

For extendible boom cranes like the one shown, the extend or retract boom mode, sometimes referred to as crowding, is used to lengthen or shorten the boom.

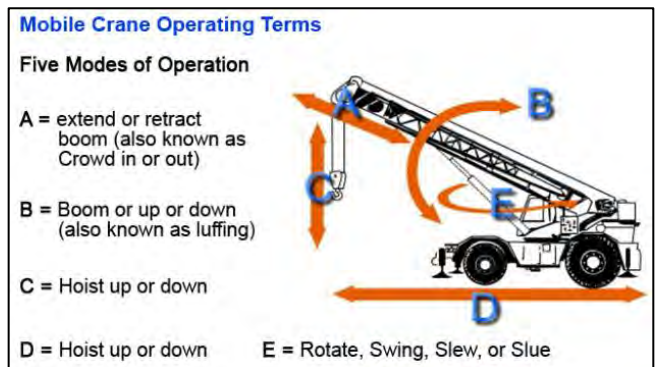

---

---

---

### Mobile Cranes - Traveling

Follow all OEM directions for transiting the crane. When transiting a truck, rough-terrain, all-terrain, or crawler crane to and from job sites, secure the hook and block to the carrier frame to prevent them from swinging into the boom.

When securing the hook block, raise it just enough to take up the slack. Do not overtighten. A weak link connection shall be used to secure the hook block to the crane. The breaking strength of the connecting piece shall be less than the rated load of the hook block's wire rope as reeved.

When securing the hook blocks for highway travel, add a back-up (stronger) tie-back to prevent free swinging in the event of weak link failure. Ensure there are adequate clearances.

Unless otherwise allowed by the OEM, the boom shall be carried in line with the direction of transit. Additionally, the superstructure shall be secured against rotation.

### Mobile Cranes - Operating

When lifting and landing heavy loads with mobile cranes, adjust the boom position as necessary to compensate for deflection. The signal person should assist in keeping the boom tip directly over the load. Use the shortest boom length practical for maximum stability and strength. Use power lowering for positive load control.

---

---

---

#### Mobile Cranes - Traveling



- Follow OEM directions for transiting the crane
- Secure the hook and block to the carrier frame
- When securing hook blocks for highway travel, add an additional tie-back
- Ensure adequate clearances
- Secure the superstructure against rotation

---

---

---

---

---

---

#### Mobile Cranes - Operating

- Adjust for boom deflection with heavy loads
- Use the shortest boom practical
- Use power lowering for positive load control



### Engaging the Rotate Lock

The rotate locking device should be engaged whenever the operator leaves the cab or controls, while the crane is traveling with a load in “pick and carry” mode (if required by the Original Equipment Manufacturer), and any other time required by the crane Original Equipment Manufacturer.

---

---

---

#### Engaging the Rotate Lock



Engage the rotate locking device:

- Whenever the operator leaves the cab or controls
- While the crane is traveling (if required by the OEM)
- Any other time required by the OEM

### Knowledge Check

1. **Select the best answer.** There are five common modes of operation for a mobile crane. The arrow in this image depicts which operational mode?

- A. Booming up or down
- B. Extend or Retract Boom
- C. Hoist up or down
- D. Rotate



2. **Select the best answer.** There are five common modes of operation for a mobile crane. The arrow in this image depicts which operational mode?

- A. Booming up or down
- B. Extend or Retract Boom
- C. Hoist up or down
- D. Rotate



3. **Select the best answer.** There are five common modes of operation for a mobile crane. The arrow in this image depicts which operational mode?

- A. Booming up or down
- B. Extend or Retract Boom
- C. Hoist up or down
- D. Rotate



4. **Select the best answer to fill in the blank.** When moving a truck, cruiser, or crawler crane to and from job sites, always secure the \_\_\_\_\_ to the carrier frame.

- A. Hooks
- B. Jacks
- C. Jib
- D. Oiler
- E. Rigging gear

5. **Select the best answer.** When lifting heavy loads with mobile cranes, operators must keep in mind what specific precaution?

- A. Adjust as necessary for boom deflection before lifting the load
- B. Remove stowed jib to lighten the boom
- C. Use both hooks for added capacity

### Lifting on Tires

Lift on rubber only when necessary and allowed. Cranes are much less stable on rubber than when on outriggers. Lift only on level surfaces. Remember, greater deflection and radius increase can be expected when making lifts on tires.

---

---

---

### Lifting on Tires - Issues

Check all tires for condition and inflation to OEM specifications. Axle lockouts must be tested according to OEM instructions to ensure proper operation.

---

---

---

**Lifting on Tires**

- Lifting on tires
- Lift only on level supporting surfaces
- Greater deflection (and radius increase)

A diagram showing a mobile crane with its boom extended and a load suspended. The crane is positioned on a surface that is slightly uneven, illustrating the concept of lifting on tires. The crane's outriggers are not fully extended, and the load is being lifted from the ground level.

**Lifting on Tires - Issues**

Check for:

- Condition
- Inflation pressure
- Axle lockout function

A close-up photograph of a black tire mounted on a yellow metal rim. The tire appears to be in good condition with visible tread patterns.



### Using Extensions on Tires

Check the crane’s manual and load chart information before using a jib or extension. Lifting from jibs or boom extensions while on rubber is prohibited by most manufacturers.

---



---



---



### On Tires Load Chart

When lifting on rubber is permitted at your activity, you must use the appropriate on-rubber load charts. This chart shows gross capacities when working on tires. The OEM may provide on rubber charts for stationary 360 degrees, locked over-the-front, defined arc over-the-front, and pick & carry. Check the working area diagram before lifting on tires.

---



---



---

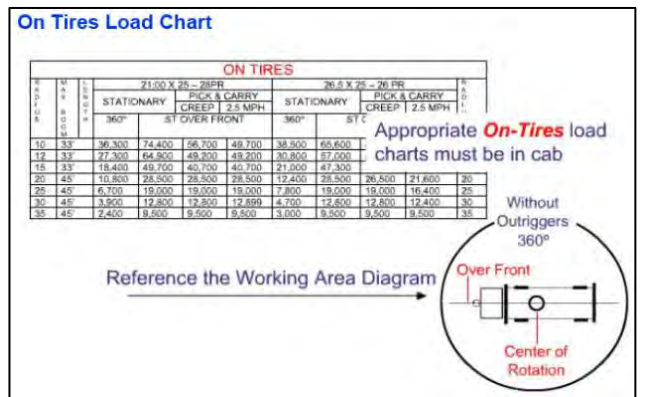

### Crane Center of Gravity

It is important for operators to understand how the center of gravity affects the capacity of the crane when moving from one quadrant to another. The illustration shows a crane on-rubber positioned for lifting over the side and over the rear. The symbol on each crane represents the center of gravity of the entire crane including the carrier. The tipping axis for the crane in each position is the centerline of the outer tires. A crane becomes less stable with the same load applied whenever the center of gravity of the crane moves closer to the tipping axis. This is why most mobile cranes have a higher over-the-rear capacity than over-the-side.

---



---

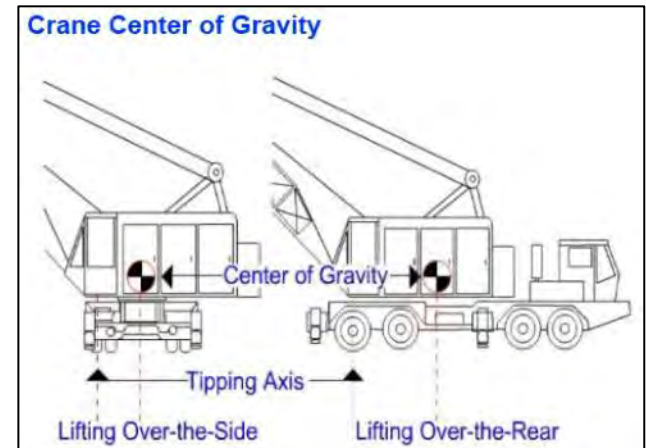

### Mobile Cranes – Traveling with Loads

Travel with suspended loads only when permitted by the OEM and the local activity. Cranes must have appropriate *Pick and Carry Load Charts* in the operator’s cab. Set the rotate lock and travel with the load directly over the end in line with the carrier as required by the OEM. Generally, this means carrying over the front with RT cranes and over the rear with truck cranes. Rotate brakes are normally used for holding operating position when the crane is not in line with the crane carrier. When practical and as permitted by the OEM, extend the outriggers and keep the outrigger pads a few inches off the ground. Always check that the automatic or manual axle lock-outs, when equipped, are released. Be sure the ground which the crane will travel over can support the machine.

**Mobile Cranes - Traveling with Loads**

- Only when allowed by the manufacturer
- Set rotate lock with load over the end
- Extend outriggers and raise the outrigger pads a few inches off the ground, when practical
- Check axle lockout operation
- Consider ground support.
- Short and low boom
- Load close in



---

---

---

---

### Extendable Boom Cranes - Operating

Lower the hoist block when extending the boom to prevent the block from raising into the limit as the boom is extended. This could result in two-blocking and break the hoist wire rope, dropping the load. Remember that anti two-block devices are operational aids that can fail and must not be relied upon to stop the movement of the hoist. Extend counterweights as required on cranes so equipped. On hydraulic truck cranes, set the front stabilizer float, when equipped. Check the operator’s manual and load chart notes for instructions on setting the stabilizer float. In many cases, it must be set regardless of the quadrants of operation.

**Extendable Boom Cranes - Operating**

- Lower Hoist(s) while extending booms

**If equipped:**

- Extend counterweight
- Set front float

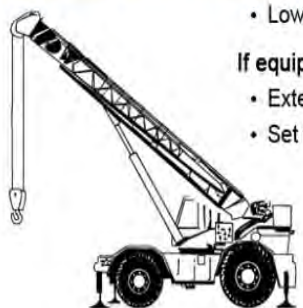

---

---

---

### Extendable Boom Cranes - Securing

When securing a truck crane with a hydraulic boom, retract the boom fully and place it in the cradle. For rough terrain cranes, place the boom in a nearly horizontal position. Requirements for mobile extendible boom cranes may vary from manufacturer to manufacturer. Always consult OEM instructions for securing requirements for each crane.

---

---

---

### Extendable Boom Cranes - Securing

- Fully retract the boom
- Place the boom in the cradle or near horizontal position



### Mobile Lattice-Boom Cranes - Operating

When operating a mobile lattice-boom crane, lower the hoist blocks to allow boom tip clearance before lowering the boom. Lowering a fixed boom with the load block close to the boom-tip sheaves may result in two-blocking. On many lattice-boom truck cranes, you must also set the front float when equipped for on-outrigger operation. For friction machines, set hoist-drum pawls, when the hoist is not in use. When the crane is equipped with automatic hoist-drum pawls, they should be checked regularly.

---

---

---

### Mobile Lattice Boom Cranes - Operating



- Lower hoist(s) before booming down
- Set front float
- Set drum pawls when not in use

### Mobile Lattice Boom Cranes – Securing

When securing lattice-boom cranes, place the boom at approximately 45 degrees, and engage hoist drum and boom pawls. Lock down all foot brakes and then disengage the master clutch. Shut down the engine and secure the crane.

---

---

---

### Mobile Lattice Boom Cranes - Securing

- Place the boom at 45 degrees
- Engage hoist drum and boom pawls
- Lock down foot brakes
- Disengage the master clutch
- Shut down the engine
- Secure the crane



## Knowledge Check

6. **Select the best answer.** Extending the boom on a typical hydraulic crane will cause the hook(s) to—
- A. Lower
  - B. Raise
  - C. Spin
7. **Select the best answer. True or False:** On hydraulic truck cranes, set the front float or 5<sup>th</sup> outrigger, when equipped.
- A. True
  - B. False
8. **Select the best answer.** Hydraulic booms can fail with little or no warning when subjected to—
- A. Side loads
  - B. Overloads
  - C. Both A and B are correct
9. **Select the best answer to fill in the blank.** When securing rough terrain cranes, the boom should be in a near \_\_\_\_\_ position.
- A. Horizontal
  - B. Safe
  - C. Vertical
10. **Select the best answer.** All of the following steps apply to securing lattice boom cranes except—
- A. Disengage the master clutch
  - B. Engage all drum pawls
  - C. Lock down all foot brakes
  - D. Place the boom at approximately 45 degrees
  - E. Retract the boom
11. **Select the best answer. True or False:** Lowering a fixed boom with the load block close to the boom tip sheaves may result in two-blocking.
- A. True
  - B. False

### Operating Floating Cranes

When swinging or rotating floating cranes, you must start slowly and stop smoothly. Abrupt starts and stops cause barge rotation putting unnecessary strain on mooring lines.

To compensate for the list of the floating crane when lifting heavy loads from the pier, position the hook directly over the load, take a strain on the rigging, and then boom up.

---

---

---

### Securing Floating Cranes

When securing floating cranes, follow OEM and local instructions and set the boom at the recommended angle or so the hooks are over the deck anchor point. Secure the hooks to the barge using tie-down pendants with a weak link.

---

---

---

### Floating Crane Barge – Securing

Secure the floating crane barge as required. Set the gangway when the crane is moored pier-side. Clean and secure the deck. Store or secure loose cargo. Stow unused rigging gear, mooring lines, and ropes. Check mooring line tension to allow for tidal changes. **At high tide**, ensure that lines are slack enough to avoid overstressing or parting as the tide recedes. **At low tide**, snug up mooring lines to minimize barge movement as the tide rises and lines slacken. Energize exterior lighting such as anchor lights and aircraft warning lights as required. Secure personnel access areas, ladders, auxiliary machinery, and close all watertight doors and hatches.

**Floating Cranes - Operating**

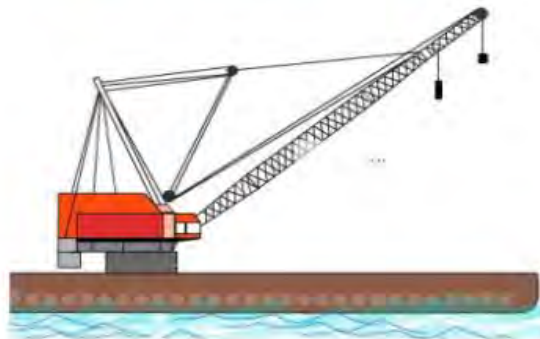

- Start rotation slowly and stop smoothly
- Compensate for listing on heavy lifts

**Floating Cranes - Securing**



- Place the boom at the recommended angle
- Secure hooks to the barge

**Floating Crane Barge - Securing**

- Set the gangway
- Clean and secure the deck
- Check mooring lines
- Energize exterior lighting
- Secure auxiliary machinery
- Close doors and hatches



---

---

---

### Portal Cranes - Operating

Travel with caution, especially in congested work areas and when approaching curves, intersections, building entrances, and access to ladders leading into dry docks. It is a good practice to stop before crossing rail switches to verify correct alignment. When possible, the operator should position the boom in the direction of travel. If the crane rigger gives a signal to travel back and disappears from sight, **the crane operator must stop traveling** until communication is reestablished. Clearance lines painted along crane tracks are a guide to keep all materials and vehicles away from crane travel trucks. Operators shall stop crane travel when materials or vehicles are inside crane clearance lines until they are moved.

### Securing Portal Cranes

When securing portal cranes, follow Original Equipment Manufacturer recommendations. Park away from fire lanes, gangways, and pedestrian walkways. When required, connect to shore power using the proper electrical safety procedures.

---

---

---

### Operating Locomotive Cranes

When operating a locomotive crane, use tilt-blocks or bed-stabilizing wedges according to OEM instructions to provide over-the-side stability for heavy lifts. Use outriggers when making lifts exceeding the free-rated capacity of locomotive cranes.

---

---

---

**Portal Cranes - Operating**



- Travel with caution in congested areas
- Stop before crossing rail switches
- Boom in the direction of travel
- Stop travel if material is on the tracks

---

---

---

**Portal Cranes - Securing**

- Park out of fire lanes and walkways
- Connect to shore power when required



**Locomotive Cranes - Operating**



- Use tilt-blocks per OEM instructions
- Use outriggers if over free-rated capacity

### Traveling Locomotive Cranes

Disengage tilt-blocks or bed-wedges when traveling and lifting over the side at the same time. Failure to do so may result in derailing the crane because of the decreased ability for the axle assemblies to pivot on the carrier when rounding corners. When traveling around corners, carry loads in the center of the tracks. When this is not possible, carry the load or counterweight, whichever is heavier, to the outside of the curved track. This will prevent the tapered travel wheels from climbing the rail and derailing the crane. Have the signal person flag traffic at street crossings. Sound the horn when approaching intersections or blind corners and use warning bells while backing up. When traveling without loads, set the boom to approximately 45 degrees.

### Locomotive Cranes – Moving Cars

If you need to move rail cars using a locomotive crane, use caution when coupling or disconnecting cars. The crane crew shall **make sure that no one is working in, on, or under the car**, and that nothing will prevent its safe movement. Crews shall uncouple cars only when brakes are set and wheels are properly chocked. Limit the number of cars moved at one time, loaded or unloaded, to the number recommended by the crane manufacturer or by local policy. Locomotive cranes are not usually designed to charge the braking systems of additional cars or to move several cars at a time.

### Securing Locomotive Cranes

When securing locomotive cranes, set the boom at about a 45 degree angle. If equipped with a magnet, clam-shell, or other lifting attachment, lower it to the ground. Set the car-body brake or place wheel wedges against the inner set of travel wheels.

---

---

---

**Locomotive Cranes - Traveling**

- Set tilt-blocks in the traveling position
- Carry loads in the center of tracks
- Use a signal person at street crossings
- Use horns and warning bells as needed
- Set the boom to 45 degrees when traveling without loads



---

---

---

**Locomotive Cranes - Moving Cars**

- Use caution when coupling
- Uncouple only after brakes are set and wheels are chocked
- Limit cars moved at one time



---

---

---

**Locomotive Cranes - Securing**

- Set the boom at 45 degrees
- Lower attachments to the ground
- Set the car-body brake or wheel wedges



### Overhead Electric Traveling (OET) and Gantry Cranes - Operations

The bridge travel function is used to travel the crane in the selected direction along the length of the runway rails. This allows the operator to move the entire crane along its supporting rail structure, in the selected direction.

The trolley travel function is used to move the hoisting machinery in the selected direction along the trolley rails.

The hoist function is used to raise and lower the hooks.

---

---

---

### OET and Gantry Cranes - Operating

Overhead electric traveling cranes are generally operated indoors, so congestion is often an issue. Watch for changes in the work area that may cause interference. Storage racks with material stacked too high are a common problem. Operators should always check for trolley and bridge drift before operating the crane. Lift loads vertically. Side pulls can cause uneven or overlapped spooling of the hoist wire and may cause the wire rope to be cut or severely damaged. In addition, ensure the hook and block are not swinging prior to hoisting. Improper or overlapped spooling of the wire rope on the drum can occur with or without a load on the hook when hoisting. Avoid sudden starts and stops with the bridge. This can result in skidding and uneven wear on the wheels. A sudden start with a heavy load on one end of the bridge may cause a crane to skew. Skewing means that the bridge and trucks are out of alignment with the rails, often resulting in wheel chatter from flange contact with the sides of the rail head.

#### OET and Gantry Cranes - Operations



- The bridge travel function is used to travel the crane along the rails.
- The trolley function is used to move the hoisting machinery along the trolley rails.
- The hoist function is used to raise and lower the block and hook.

#### OET and Gantry Cranes - Operating

- Watch for travel interference
- Check for trolley and bridge drift
- Lift loads vertically
- Avoid sudden starts and stops



**Warning:** Hoisting with the hook or block swinging can result in improper or mis-spooling of the wire rope on the drum with or without a load on the hook.

---

---

---

---

---



### OET and Gantry Cranes – Operating (Continued)

Always board cab-operated cranes at designated places. Access the crane cab or bridge walkway using fixed ladders, stairs, or platforms. Remain aware of other cranes working on the same rail system. For gantry cranes, watch travel truck clearances. For cab-operated gantry cranes, this may require additional personnel to ensure a clear travel path. Use radio controls according to the manufacturer’s instructions. Turn off power to the radio controller and properly store when finished operating.

---

---

---

#### OET and Gantry Cranes - Operating

- Board cab-operated cranes at designated places
- Remain aware of other cranes on the same rail
- For gantry cranes, watch travel truck clearances
- Use radio controls per OEM instructions



### Securing the Crane

Move cab-operated cranes to a boarding platform or ladder. Never attempt to walk the rails to enter or exit an Overhead Electric Traveling (OET) crane. Ensure that crane power is turned off, and the lower block is not an obstruction. Do not store the hook block in the upper limit unless allowed by the OEM or activity instruction. Additionally, provide sufficient clearance below the upper sheave assembly or trolley so that the subsequent operator performing a pre-use check will be able to stop the hoist motion before a two-block event occurs in case the hoist does not operate in the correct direction upon initiation.

When necessary for OET or gantry cranes located outside, secure the crane against movement by the wind. Chock the travel trucks or wheels as necessary.

Activities are required to develop instructions for securing WHE in adverse weather conditions. Operators shall be aware of these requirements.

#### Securing the Crane



- Move cab-operated cranes to a boarding platform or ladder
- Raise hook blocks near, but not in the limit switch
- Secure crane power
- Secure the crane against movement

---

---

---

---

---

---

---

## Knowledge Check

- 12. Select the best answer. True or False:** When operating floating cranes, you must start swinging or rotating quickly and stop abruptly.
- A. True
  - B. False
- 13. Select the best answer.** Lifting heavy loads with floating cranes will cause the barge to—
- A. Drift
  - B. List
  - C. Rotate
  - D. Sink
  - E. Skew
- 14. Select the best answer. True or False:** Portal crane operators shall stop crane travel if materials or vehicles are inside crane clearance lines.
- A. True
  - B. False
- 15. Select the best answer to fill in the blank.** When making heavy lifts with locomotive cranes, the use of tilt-blocks or bed-wedges will increase \_\_\_\_\_ stability.
- A. On outriggers
  - B. On rubber
  - C. Over the end
  - D. Over the side
- 16. Select the best answer.** Failure to disengage tilt-blocks or bed-wedges for locomotive crane travel may result in—
- A. Derailing the crane
  - B. Loss of stability
  - C. Overheating brakes
  - D. Overloading the crane
- 17. Select the best answer.** Which of the following is a mode of operation for a typical OET or gantry crane?
- A. Hoist
  - B. Luff
  - C. Skew
- 18. Select the best answer.** Which of the following is a mode of operation for a typical OET or gantry crane?
- A. Hoist
  - B. Luff
  - C. Swing

**19. Select the best answer.** Which of the following is a mode of operation for a typical OET or gantry crane?

- A. Bridge
- B. Extend
- C. Rotate

Completion

---

---

---

Completion

**Congratulations.**

**You have completed Safe Operations Module 2.**

Click on the Exit button to return to the main module menu.

## CRANE AND RIGGING ACCIDENTS

### Welcome

Welcome to Crane and Rigging Accidents.

---

---

---

### Learning Objectives

Upon successful completion of this module, you will be able to identify the elements in the crane and rigging operating envelopes, define a crane accident, define a rigging accident, near miss, and unplanned occurrence, identify the primary causes of accidents, and explain the procedures to follow when an accident occurs.

---

---

### Accident Categories

There are two general categories of accidents: crane accidents and rigging accidents. Crane accidents are those that occur during operation of a category 1, 2, 3, or 4 crane.

Rigging accidents are those that occur when gear and equipment identified in Section 14 is used by itself in a weight handling operation, for example without category 1 through 4 cranes, or when covered gear is used with multi-purpose machines, Material Handling Equipment (for example forklifts), and equipment covered by NAVFAC P-300 in a weight handling operation.

In addition, accidents that occur during the operation of entertainment hoists shall be classified as rigging accidents.

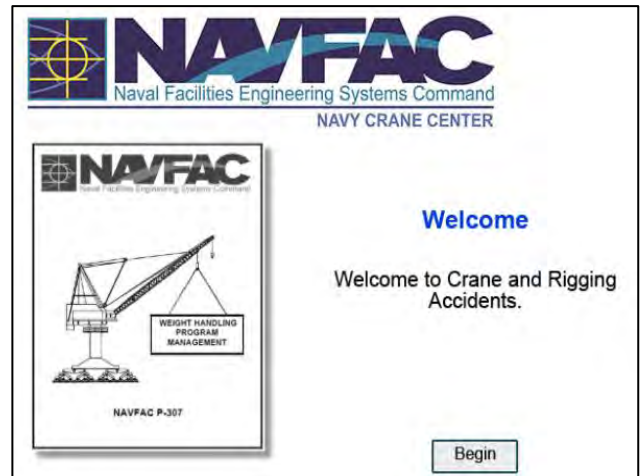

### Learning Objectives

Upon successful completion of this module, you will be able to:

- Identify the elements in the crane and rigging operating envelopes
- Define a crane accident
- Define a rigging accident, near miss, and unplanned occurrence
- Identify the primary causes of accidents
- Explain the procedures to follow when an accident occurs

### Accident Categories

There are two general categories of weight handling accidents: Crane Accidents and Rigging Accidents.

- A crane accident occurs during the operation of a Category 1, 2, 3, or 4 crane.
  - Rigging accidents are those that occur when gear and equipment identified in Section 14 is used by itself in a weight handling operation, or when covered gear is used with multi-purpose machines, MHE and equipment covered by NAVFAC P-300 in a weight handling operation.
  - Accidents that occur during the operation of entertainment hoists shall be classified as rigging accidents.
- 
- 
-

### Significant Accidents

A significant accident is an accident that typically has a greater potential to result in serious injury or substantial property damage. The following accident types are considered significant accidents: injuries regardless of severity, overloads, dropped loads, two-blocks, crane derailments, or contact with overhead electrical power lines. Other types of accidents that result in OPNAV Class A, B, C, or D reporting thresholds for material property damage are also considered significant accidents.

---

---

---

**Significant Accidents**

**Significant accidents include:**

- Injuries
- Overloads
- Dropped Loads
- Two-blocks
- Crane derailments
- Contact with overhead electrical power lines

### Crane Operating Envelope

To define a crane accident, you must first understand the crane operating envelope. The operating envelope consists of any of the following elements: the crane (except a crane being operated in transit as defined in NAVFAC P-307 Appendix A), the operator, the riggers, signal persons, and crane walker, other personnel involved in the operation, the rigging gear between the hook and the load, the load, the crane's supporting structure (ground, rail, etc.), and the lift procedure.

---

---

**Crane Operating Envelope**

The crane operating envelope consists of any of the following elements:

- the crane
- the operator
- the riggers, signal persons, and crane walker
- other personnel involved in the operation
- the rigging gear between the hook and the load
- the load
- the crane's supporting structure
- the lift procedure



### Rigging Operating Envelope

The operating envelope around any rigging or other Section 14 equipment operation includes the rigging gear or miscellaneous equipment identified in Section 14, the user of the gear or equipment (including operators of multi-purpose machines, material handling equipment, and construction equipment), other personnel involved in the operation, the load, the gear or equipment's supporting structure (padeyes, ship's structure, building structure, etc.), the load's rigging path, and the rigging or lift procedure.

---

---

**Rigging Operating Envelope**

**Includes:**

- Rigging gear or miscellaneous equipment in Section 14
- The user of the gear or equipment
- Other personnel involved in the operation
- The load
- The gear or equipment's supporting structure
- The load's rigging path
- The rigging or lift procedure



### Knowledge Check

1. **Select all that apply.** The crane operating envelope includes the crane, the operator, the riggers, the crane walkers, and—
  - A. any supporting structures
  - B. rigging gear between the hook and the load
  - C. the area where the load will be landed
  - D. the load
  
2. **Select all that apply.** The rigging operating envelope contains the rigging gear and miscellaneous equipment covered by P-307 Section 14, the load itself, and—
  - A. other personnel involved in the operation
  - B. the crane removal procedure
  - C. the gear or equipment's supporting structure
  - D. the load rigging path
  - E. the rigging procedure
  - F. the user of the gear or equipment

### Near Miss

A near miss is an unplanned event during a weight handling operation that did not result in a definable accident but easily had the potential to do so. Only a break in the chain of events prevented an accident. Simply put, a near miss is an accident that almost took place. The difference between a near miss and an accident (serious or otherwise) is often a fraction of an inch or a split second of time. A near miss report is used to learn from situations where an accident "almost" happened so that the real event can be averted.

---

---

---

**Near Miss**

- A near miss is an unplanned event during a weight handling operation that did not result in a definable accident but easily had the potential to do so.
- A near miss report is used to learn from situations where an accident "almost" happened so that the real event can be averted.

### Unplanned Occurrence

An "unplanned occurrence" describes an event that does not meet the definition of a crane or rigging accident but results in injury or damage to a crane, crane component, or related equipment due to an event not directly related to a weight handling operation. Examples include, but are not limited to, injury or damage caused by weather, damage to a parked or stationary crane caused by another moving object (e.g. vehicle, forklift), and flooding or fire damage.

---

---

---

### Near Miss Reporting

Near Misses and unplanned occurrences that do not fall under the crane and rigging accident definitions shall be reported using Figure 12-2 (available on the Navy Crane Center website). These reports shall be submitted in accordance with NAVFAC P-307 Section 12 within 30 days of the event.

---

---

### Crane Accident

A crane accident occurs when any of the elements in the crane operating envelope fails to perform correctly during a crane operation including operation during maintenance or testing resulting in any of the following: personnel injury or death, material or equipment damage, dropped load (including any part of the load or rigging gear and any item lifted with the load or rigging gear), derailment, two-blocking, overload (including load tests when the nominal test load is exceeded), or collision (avoidable contact between the load, crane, and/or other objects).

---

---

---

#### Unplanned Occurrence

An "unplanned occurrence" describes an event that does not meet the definition of a crane or rigging accident but results in injury or damage to a crane, crane component, or related equipment due to an event not directly related to a weight handling operation.

Examples include:

- Injury or damage caused by weather
- Damage to a parked or stationary crane caused by another moving object
- Flooding or fire damage

#### Reporting

- Near misses and unplanned occurrences shall be reported using the Near Miss and Unplanned Occurrence Report (Figure 12-2).
- These reports shall be submitted within 30 days of the event.

#### Crane Accidents Occur—

When any of the elements in the crane operating envelope fails to perform correctly during a crane operation including operation during maintenance or testing resulting in any of the following:

- Personnel injury or death
- Material or equipment damage
- Dropped load
- Derailment
- Two-blocking
- Overload
- Collision



### Rigging Accidents

A rigging accident occurs when any of the elements in the operating envelope fails to perform correctly during a rigging operation resulting in any of the following: personnel injury or death, material or equipment damage that requires the damaged item to be repaired because it can no longer perform its intended function, dropped load (including any part of the load or rigging gear and any item lifted with the load or rigging gear), two-blocking of cranes and powered hoists identified in Section 14, or overload (including load tests when the test load tolerance is exceeded).

**Note:** A dropped load, two-blocking, and overload are considered accidents even though no material damage or injury occurs.

---

---

---

### Damaged Rigging Gear

When damage to rigging gear is discovered during an inspection or when damaged rigging gear is returned to the gear room and an accident is suspected, the gear shall be immediately removed from service and a comprehensive investigation initiated.

For a suspected accident, the activity shall follow the investigation and reporting requirements of NAVFAC P-307 Section 12, promptly perform a comprehensive investigation and prepare a Crane and Rigging Accident Report, and forward a copy to the Navy Crane Center (Code 06) within 30 days of the accident.

Local Weight Handling Equipment accident reporting procedures shall also be followed.

#### Rigging Accidents

Occur when any of the elements in the operating envelope fails to perform correctly during a rigging operation resulting in any of the following:

- Personnel injury or death
- Material or equipment damage
- Dropped load
- Two-blocking
- Overload



**Note:** A dropped load, two-blocking, and overload are considered accidents even though no material damage or injury occurs.

#### Damaged Rigging Gear

When damage to rigging gear is discovered during an inspection or when damaged rigging gear is returned to the gear room AND an accident is suspected—

- Immediately remove the gear from service
- A prompt comprehensive investigation shall be performed
- The incident shall be documented on a Crane and Rigging Accident Report and forwarded to the Navy Crane Center within 30 days



**Note:** Local WHE accident reporting procedures shall also be followed.

---

---

---



### Accident Examples

Some common examples of accidents are dropped loads, injuries from a shifting load, failure of rigging gear resulting in a dropped load, overloads, and improperly secured loads falling from pallets.

---

---

---

**Accident Examples**



- Dropped loads
- Injuries from shifting loads
- Rigging gear failure
- Overloads
- Load falls off of pallet

### Accident Exception

A component failure (e.g., motor burnout, gear tooth failure, bearing failure) shall be considered an accident only if damage to the load or another component occurs as a result of the failure.

---

---

---

**Accident Exception**

Component failure is considered an accident only if damage to the load or another component occurs as a result of the failure.



### Accident Causes

In most cases, crane accidents result from personnel error and can be avoided. Most crane accidents are caused by inattention to the task, poor judgment, bad communication, team members having too much confidence in their abilities, or operating the crane too fast.

---

---

**Accident Causes**

In most cases, crane accidents result from personnel error and can be avoided.

In most cases, crane accidents are due to:

- Inattention to the task
- Poor judgment
- Overconfidence
- Excessive speed

### Operator Responsibilities

The operator can play a significant role in eliminating human error and accidents. Drugs and alcohol can affect a person's capability to think, reason, or react in normal situations and can certainly lead to serious accidents. Operators must always consult their physicians regarding effects of prescription drugs before operating equipment and recognize that medications often affect people

**Operator Responsibilities**

Drugs and alcohol can affect a person's ability to think or react normally and can lead to accidents.

Operators shall:

- Consult their physician regarding effects of medications
- Evaluate his or her own physical and emotional fitness
- Inform their supervisor of conditions as appropriate

differently. An operator is responsible for evaluating his or her physical and emotional fitness.

---

---

---

### WHE Accident Response

Upon having an accident or having seen evidence of damage, the crane team, riggers, equipment users, etc., shall stop all operations and notify immediate supervisor(s). If there is impending danger to the equipment or personnel, place the crane and/or load in a safe position prior to notifying supervision. Ensure the accident scene is secured and undisturbed so as to facilitate the investigation. The supervisor shall review the situation and take any further emergency action. The supervisor shall notify management personnel as well as the activity safety office.

#### WHE Accident Response

- Upon having an accident or having seen evidence of damage, stop all operations and notify immediate supervision.
- If there is impending danger to the equipment or personnel, place the crane and/or load in a safe position prior to notifying supervision.
- Secure the accident scene.
- The supervisor shall review the situation, take any further emergency action, and notify management personnel as well as the activity safety office.

---

---

---

### Notification and Reporting

For accidents involving a fatality, inpatient hospitalization, overturned crane, collapsed boom, or any other major damage to the crane, load, or adjacent property, notify the Navy Crane Center by e-mail as soon as practical but not later than eight hours following the accident. Notification for all other accidents shall be made as soon as practical but no later than three working days after the accident. For each suspected accident, activities shall promptly perform an investigation, prepare a crane and rigging accident report using Figure 12-1 (available on the Navy Crane Center website), and forward a copy to the Navy Crane Center (Code 06) within 30 days of the accident.

---

---

---

#### Notification and Reporting

For accidents involving a fatality, inpatient hospitalization, overturned crane, collapsed boom, or any other major damage to the crane, load, or adjacent property, notify the Navy Crane Center by e-mail (navfac\_ncc\_accident@us.navy.mil) as soon as practical but not later than eight hours following the accident.

For all other accidents, the Navy Crane Center must be notified as soon as practical but no later than three working days after the accident.

For each suspected accident, activities shall promptly perform an investigation, prepare a Crane and Rigging Accident Report, and forward a copy to the Navy Crane Center (Code 06) within 30 days of the accident.

### Contractor Accident Reporting Procedures

The contractor shall notify the contracting officer as soon as practical, but not later than four hours, after any Weight Handling Equipment accident, secure the accident site and protect evidence until released by the contracting officer, and conduct an investigation to establish the root cause(s) of any Weight Handling Equipment accident, near miss, or unplanned occurrence.

Crane operations shall not proceed until the cause is determined and corrective actions have been implemented to the satisfaction of the contracting officer.

The contractor shall provide the contracting officer a report for an accident or near miss within 30 days using the appropriate form provided in NAVFAC P-307 Section 12 consisting of a summary of circumstances, an explanation of causes, photographs (if available), and corrective actions taken.

### Contracting Officer Reporting Procedures

The contracting officer shall notify the host activity of any Weight Handling Equipment accident upon notification by the contractor. Additionally, the contracting officer shall notify the Navy Crane Center, by e-mail (navfac\_ncc\_accident@us.navy.mil), of an accident involving a fatality, inpatient hospitalization, overturned crane, collapsed boom, or any other major damage to the crane or adjacent property as soon as possible, preferably within 8 hours of notification by the contractor. For all other accidents, notify the Navy Crane Center as soon as practical but no later than three working days after the accident.

The contracting officer shall provide the Navy Crane Center and host activity a copy of every accident and near miss report, regardless of severity, upon receipt from the contractor.

The contracting officer or designated weight handling representative shall sign all crane and rigging accident and near miss reports to indicate that they are satisfied that the contractor's investigation and corrective action are sufficient.

**Reporting Procedures - Contractor**

The contractor shall:

- Notify the contracting officer as soon as practical but no later than four hours after any WHE accident
- Secure the accident site and protect evidence until released by the contracting officer
- Conduct an accident investigation to establish the root cause(s) of any WHE accident, near miss, or unplanned occurrence

Crane operations shall not proceed until cause is determined and corrective actions have been implemented to the satisfaction of the contracting officer.

The contractor shall provide the contracting officer a report for an accident or near miss within 30 days using the appropriate form provided in NAVFAC P-307 Section 12.

---

---

---

---

---

---

---

---

**Reporting Procedures - Contracting Officer**

The contracting officer shall:

- Notify the host activity of any WHE accident upon notification by the contractor
- Provide the Navy Crane Center and the host activity a copy of every accident report, regardless of severity, upon receipt from the contractor
- Notify the Navy Crane Center of any accident involving a fatality, inpatient hospitalization, overturned crane, collapsed boom, or any other major damage to the crane, load, or adjacent property as soon as possible, preferably within 8 hours of notification by the contractor

The contracting officer or designated weight handling representative shall sign all crane and rigging accident and near miss reports to indicate that they are satisfied that the contractor's investigation and corrective action are sufficient.

---

---

---

---

---

---

---

---

### Knowledge Check

3. **Select the best answer.** During maintenance, the rigging gear between the crane hook and the load fails and results in equipment damage. This is reported as a(n)—
  - A. crane accident
  - B. operator error
  - C. rigger error
  - D. rigging gear deficiency
  
4. **Select the best answer.** During crane operations, the load shifts. The operator reacts quickly and saves the load but causes the crane to derail. This is reported as a(n)—
  - A. crane accident
  - B. crane walker's error
  - C. load configuration error
  - D. operator error
  
5. **Select the best answer.** When rigging gear covered by NAVFAC P-307 Section 14 fails while suspended from a structure and drops the load, it is a—
  - A. crane accident
  - B. load configuration error
  - C. rigging accident
  - D. rigging error
  
6. **Select the best answer.** If component failure occurs, such as motor burnout, and does not result in damage, the component failure is considered—
  - A. a crane accident
  - B. a non-accident
  - C. crane maintenance's responsibility
  - D. rigging accident
  
7. **Select the best answer.** To whom or to what are the majority of crane accidents attributed?
  - A. crane operators
  - B. equipment failure
  - C. personnel error
  - D. riggers or signalmen
  - E. weather conditions

8. **Select all that apply.** Overconfidence and poor judgement among team members can contribute to crane and rigging accidents. Select additional factors that can contribute to accidents.
- A. engineering lift specifications
  - B. inattention to the task
  - C. operating the crane too fast
  - D. the crane operating envelope
9. **Select all the best answer.** If you have an accident with a crane or you find damage and suspect an accident has happened, your first step is to—
- A. Call emergency services if anyone is injured.
  - B. Notify your supervisor immediately.
  - C. Secure the crane and power as require
  - D. Stop operations as soon as safely possible



**GENERAL CRANE SAFETY REFRESHER EVALUATION SHEET**

**Student Name:** \_\_\_\_\_

**Command/Activity/Organization:** \_\_\_\_\_

**Instructor:** \_\_\_\_\_ **Date:** \_\_\_\_\_

**Directions:** To assist in evaluating the effectiveness of this course, we would like your reaction to this class.

Do not rate questions you consider not applicable.

<b>Please rate the following items:</b>	<b>Excellent</b>	<b>Very Good</b>	<b>Good</b>	<b>Fair</b>	<b>Poor</b>
Content of the course met your needs and expectations.					
Content was well organized.					
Materials/handouts were useful.					
Exercises/skill practices were helpful.					
Training aids (slides, videos, etc.) were used effectively.					
Instructor presented the material in a manner which was easy to understand.					
Instructor was knowledgeable and comfortable with the material.					
Instructor handled questions effectively.					
Instructor covered all topics completely.					
Probability that you will use ideas from the course in your work.					
Your opinion of the course.					
Your overall opinion of the training facilities.					

**What were the key strengths of the training? How could the training be improved? Other comments?**

\_\_\_\_\_

\_\_\_\_\_

\_\_\_\_\_

**List other training topics in which you are interested:** \_\_\_\_\_

\_\_\_\_\_

\_\_\_\_\_

**Note:** If you would like a staff member to follow up and discuss this training, please provide your phone number

\_\_\_\_\_

